

April 28, 2009

U. S. Nuclear Regulatory Commission  
Document Control Desk  
Washington, DC 20555

Subject: **Docket No. 50-362**  
**Special Report: Inspection of Steam Generator Tubes, Cycle 15**  
**San Onofre Nuclear Generating Station, Unit 3**

Dear Sir or Madam:

San Onofre Nuclear Generating Station Unit 3 entered Mode 4 on November 30, 2008 following the completion of an inspection of steam generator tubes during the Cycle 15 Refueling Outage. Technical Specification (TS) 5.7.2.c states "A report shall be submitted within 180 days after the initial entry into MODE 4 following completion of an inspection performed in accordance with the Specification 5.5.2.11, Steam Generator (SG) Program."

Accordingly we have attached the required report. The report contains no new commitments.

If you require any additional information, please contact Geoff Cook at (949) 368-9008.

Sincerely,



Attachment

cc: E. E. Collins, NRC Regional Administrator, Region IV  
R. Hall, NRC Project Manager, San Onofre Units 2, and 3  
G. G. Warnick, NRC Senior Resident Inspector, San Onofre Units 2 & 3

## **SPECIAL REPORT - INSPECTION OF STEAM GENERATOR TUBES**

### **Regulatory Reporting Requirements**

Reporting Requirement 5.7.2.c of Appendix A, Technical Specification to Facility Operating License NPF-15 requires a report of steam generator tube inspections to be submitted to the Nuclear Regulatory Commission within 180 days after the initial entry into MODE 4 following completion of an inspection performed in accordance with the Specification 5.5.2.11, Steam Generator (SG) Program. The report shall include:

1. The scope of inspections performed on each SG,
2. Active degradation mechanisms found,
3. Nondestructive examination techniques utilized for each degradation mechanism,
4. Location, orientation (if linear), and measured sizes (if available) of service induced indications,
5. Number of tubes plugged or repaired during the inspection outage for each active degradation mechanism,
6. Total number and percentage of tubes plugged or repaired to date,
7. The results of condition monitoring, including the results of tube pulls and in-situ testing,
8. The effective plugging percentage for all plugging and tube repairs in each SG, and
9. Repair method utilized and the number of tubes repaired by each repair method.

### **Inspection Scope**

Table 1 summarizes the scope of inspections performed on each SG. Also, when indications by the bobbin probe were non-quantifiable or distorted, the inspection scope included inspection with the Plus Point Probe. There were no significant inspection scope expansions in response to inspection results.

**TABLE 1 – Scope of Inspections Performed: Unit 3 Cycle 15 (U3C15) Refueling Outage**

Inspection Scope	SG E-088 Tubes/Percent	SG E-089 Tubes/Percent
Full length of tube with the bobbin probe (excluding U-bends for Rows 1-3)	8617/100%	8688/100%
Hot leg expansion transition at the top-of-tubesheet with the Plus Point Probe to an extent of 4 inches above to 13 inches below the top-of-tubesheet	8617/100%	8688/100%
Cold leg expansion transition at the top-of-tubesheet with the Plus Point Probe to an extent of 2 inches above to 13 inches below the top-of-tubesheet	2494/28%	2502/28%
U-bend regions of Rows 1, 2, and 3 with both mid-frequency and high-frequency Plus Point Probes	184/100%	174/100%
U-bend regions of Rows 4 through 10 with the mid-frequency Plus Point Probe (Note 1)	90/21%	90/20%
Plus Point Probe examination of tube support intersections with dents greater than, or equal to, 2 volts	328/100%	359/100%
Plus Point Probe examination of dings greater than, or equal to, 4 volts	307/100%	482/100%
Plus Point Probe examination of all tube support intersections with quantified wear indications by the bobbin probe	795/100%	505/100%

Table 1 Note 1: No indications in a 100% inspection performed in 2004.

**Results of the Inspection of Tubes**

Table 2 summarizes the degradation found and number of tubes plugged. The Appendices provide detail.

No degradation was found in:

- the cold leg tubesheet region
- tubing bends
- dings in tubing freespan

A robotic visual inspection of the untubed regions of the top of the tubesheet (i.e., tube bundle periphery and central blowdown lane) was performed on the secondary side of both Steam Generators. Two previously unretrievable analyzed foreign objects were again observed and re-verified unretrievable in the cold leg periphery of Steam Generator E-088. A single new foreign object was observed and verified lodged/unretrievable in the stay cylinder region of the central blowdown lane on the cold leg side Steam Generator E-089. Eddy current results indicate there has been no tube degradation associated with foreign objects. Preventive plugging was performed in the area associated with the new foreign object. All three of these foreign objects have an analysis for acceptability for tube integrity documented in the Corrective Action Process.

**TABLE 2 – Degradation Found and Number of Tubes Plugged  
U3C15 Refueling Outage**

Indication Orientation/Location	Steam Generator	
	E-088	E-089
Tubes with circumferentially oriented ID (initiated on the inside-diameter of the tubing wall) indications near the expansion transition at the top of the hot leg tubesheet	4	4
Tubes with circumferentially oriented OD (initiated on the outside-diameter of the tubing wall) indications near the expansion transition at the top of the hot leg tubesheet	1	0
Tubes with axially oriented OD indications near the top of the hot leg tubesheet	0	1
Tubes with axially oriented ID indications in the hot leg tubesheet region	4	3
Tubes with circumferentially oriented ID indications in the hot leg tubesheet region	1	0
Tubes with indications of wear at tube support locations	10	4
Foreign object preventive plugging	0	4
<b>Total</b>	<b>20</b>	<b>16</b>

**Examination Techniques**

Table 3 provides the list of Nondestructive Examination (NDE) techniques utilized for each degradation mechanism.

**TABLE 3 – Nondestructive Examination (NDE) Techniques Utilized for Each Degradation Mechanism**

Indication Orientation/Location	Probe Type for	
	Detection	Characterization
Circumferentially oriented and axially oriented ID indications near or below the expansion transition at the top of the hot leg and cold leg tubesheets	Plus Point	Plus Point
Axially oriented OD indications and Circumferentially oriented OD indications near the top of the hot and cold leg tubesheets	Plus Point	Plus Point
Axially oriented OD indications not associated with a tube support (freespan)	Bobbin	Plus Point
Axially oriented OD indications at tube support locations	Bobbin Plus Point (Note 1)	Plus Point Plus Point
Axially oriented ID indications at tube support locations	Bobbin Plus Point (Note 1)	Plus Point Plus Point
Indications of wear at tube support locations	Bobbin	Plus Point
Axially oriented ID indications and Circumferentially oriented ID indications in Low-Row U-bends	Plus Point	Plus Point
Circumferentially oriented ID indications at the flanks of tubing bends	Plus Point	Plus Point
Axially oriented OD indications at dings in tubing freespan (dings $\leq 5$ volts)	Bobbin	Plus Point
Axially oriented OD indications at dings in tubing freespan	Plus Point	Plus Point

Table 3 Note 1: Plus Point technique is used at dents greater than, or equal to, two volts.

**Condition Monitoring**

Condition Monitoring demonstrated that performance criteria in Technical Specifications sections 5.5.2.11.b.1 (structural integrity) and 5.5.2.11.b.2 (accident induced leakage) were met during operation prior to this inspection.

In situ pressure testing was not needed for any eddy current indications. All indications were below screening criteria of the Electric Power Research Institute (EPRI) In Situ Pressure Testing Guidelines. Table 4 contains all crack-like indications. All tubes with crack-like indications were removed from service. Voltage is the only size-related measurement for numerous indications in Table 4. This is consistent with industry guidance for tube integrity assessment. Industry guidance provides ranges of voltage measurement values for which voltage is the only needed size-related measurement. Table 4 addresses location, orientation and measured sizes of service-induced indications (except wear of tubing at tube supports). The entire population of wear indications at support structures was screened for in situ pressure testing. Appendices 3 and 4 address location and measured sizes of service-induced indications of wear of tubing at tube supports.

No tubes were removed (pulled) for destructive testing during this outage.

**TABLE 4 – Measured Sizes of Service-Induced Indications: U3C15**

SG	Row	Col	Elev	Inch	Ind	Origin	PP Volts	Depth	PDA	FLDA	PP Length	CA
88	2	40	TSH	-3.87	SAI	ID	0.74	61		55.57	0.28	
88	8	42	TSH	-2.84	SCI	ID	0.55	54	2.71			26
88	11	119	TSH	-0.11	MCI	ID	0.46					
88	22	34	TSH	-0.11	SCI	ID	0.61	68	3.48			26
88	31	55	TSH	+0.10	SCI	OD	0.20					
88	31	139	TSH	-0.18	MCI	ID	0.40					
88	36	112	TSH	-5.75	SAI	ID	0.36					
88	36	112	TSH	-3.68	SAI	ID	0.37					
88	36	112	TSH	-2.82	SAI	ID	0.34					
88	36	112	TSH	-2.64	SAI	ID	0.50					
88	38	112	TSH	-1.31	SAI	ID	0.69	51		43.48	0.77	
88	44	74	TSH	-7.27	SAI	ID	0.54	45		51.57	0.14	
88	100	76	TSH	-0.07	SCI	ID	0.24					
89	27	39	TSH	-0.13	SCI	ID	0.27					
89	31	125	TSH	+0.02	SCI	ID	0.42					
89	36	68	TSH	-1.58	MAI	ID	0.51	37		30.83	0.17	
89	63	89	TSH	-1.33	SAI	ID	0.55	61		50.85	0.13	
89	63	89	TSH	-1.65	SAI	ID	0.39					
89	66	76	TSH	+0.70	SAI	OD	0.19					
89	66	76	TSH	+0.66	SAI	OD	0.10					
89	101	69	TSH	-0.11	SCI	ID	0.93	70	5.19			51
89	103	69	TSH	-0.07	SCI	ID	0.68	53	4.25			30
89	103	69	TSH	-0.09	SCI	ID	0.69	53	2.58			26
89	113	99	TSH	-7.52	SAI	ID	0.51	49		46.50	0.14	
89	113	99	TSH	-7.78	SAI	ID	0.78	54		45.35	0.17	

Table 4 Notes:

SG 88 = SG E-088

SG 89 = SG E-089

PP = Plus Point

Depth = Percent of Tube Wall Thickness

PDA = Percent Degraded Area

FLDA = Flaw-Length Degraded Area

PP Length (units of measure are inches)

CA = Crack Angle (degrees)

### **Repair Methods, Number of Tubes Repaired and Effective Plugging Percentage**

All tube plugging was performed using the design, materials, and installation methods of AREVA. A "roll" method was used for all tube plugs. The repair method of sleeving has not been used for tube repair at Unit 3. Ten (10) tubes were "stabilized" in the vicinity of the top of the tubesheet using the design, materials, and installation methods of AREVA. The design number of tubes in each SG is 9350 tubes.

**TABLE 5 - Number of Tubes Repaired and Effective Plugging Percentage**

<b>SG</b>	<b># Tubes Plugged in 3C15</b>	<b># Tubes Plugged To Date</b>	<b>Effective Plugging Percentage</b>
88	20	753	8.1
89	16	678	7.3

### **Description of Appendices**

- Appendix 1 - Steam Generator Reference Information
- Appendix 2 - Legend for Appendices 3 and 4
- Appendix 3 - Tube Inspection Summary, Steam Generator E-088
- Appendix 4 - Tube Inspection Summary, Steam Generator E-089



**Appendix 1**  
**Steam Generator Reference Information**

**Steam Generator  
CE Model 3410 Tube Support Drawing**

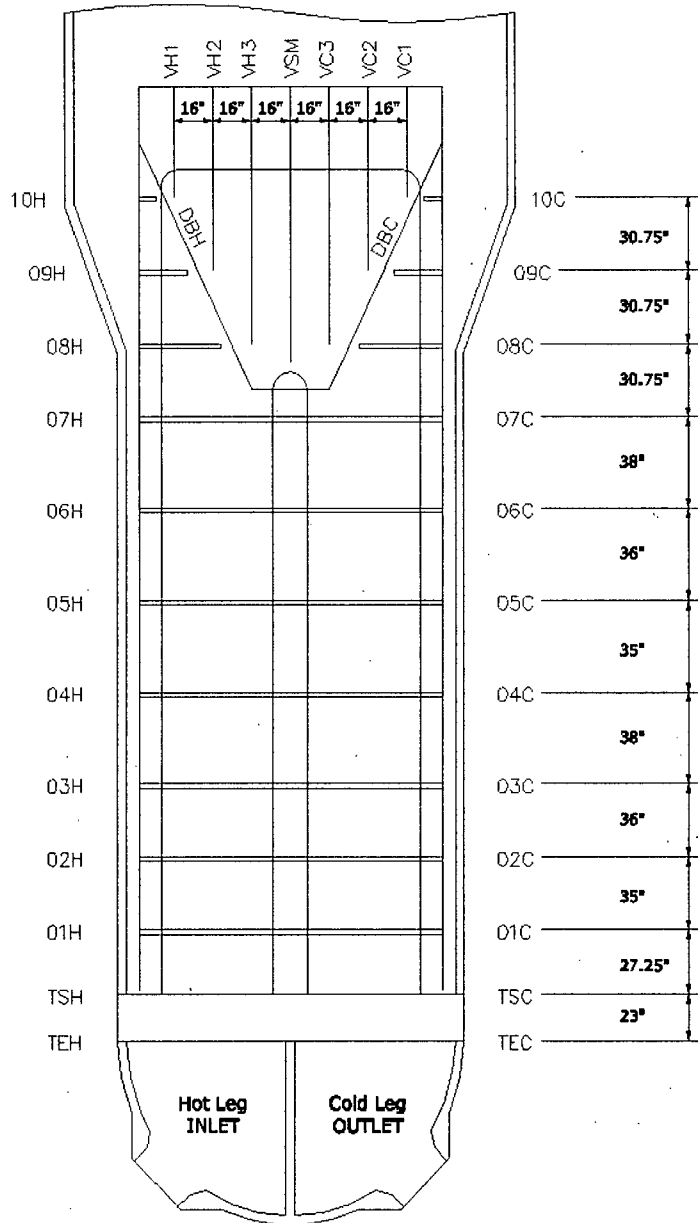

**STEAM GENERATOR TUBE SUPPORT INTERSECTIONS  
ABOVE THE 7<sup>TH</sup> (FULL) EGGCRATE SUPPORT**

<b>SUPPORT INTERSECTIONS</b>															
<b>ROW</b>	<b>STRUCTURES</b>														
122-147	08H	09H	10H	DBH	VH1	VH2	VH3	VSM	VC3	VC2	VC1	DBC	10C	09C	08C
120-121*	08H	09H	10H	DBH	VH1	VH2	VH3	VSM	VC3	VC2	VC1	DBC	10C	09C	08C
115-119	08H	09H		DBH	VH1	VH2	VH3	VSM	VC3	VC2	VC1	DBC		09C	08C
86-114	08H	09H		DBH		VH2	VH3	VSM	VC3	VC2		DBC		09C	08C
84-85*	08H	09H		DBH		VH2	VH3	VSM	VC3	VC2		DBC		09C	08C
83	08H			DBH		VH2	VH3	VSM	VC3	VC2		DBC			08C
51-82	08H			DBH			VH3	VSM	VC3			DBC			08C
49-50*	08H			DBH				VSM				DBC			08C
19-48				DBH				VSM				DBC			
1-18				DBH								DBC			

\* Indicates those rows adjacent to scallop bars

**SOUTHERN CALIFORNIA EDISON, SAN ONOFRE**

**CE MODEL 3410 STEAM GENERATOR**

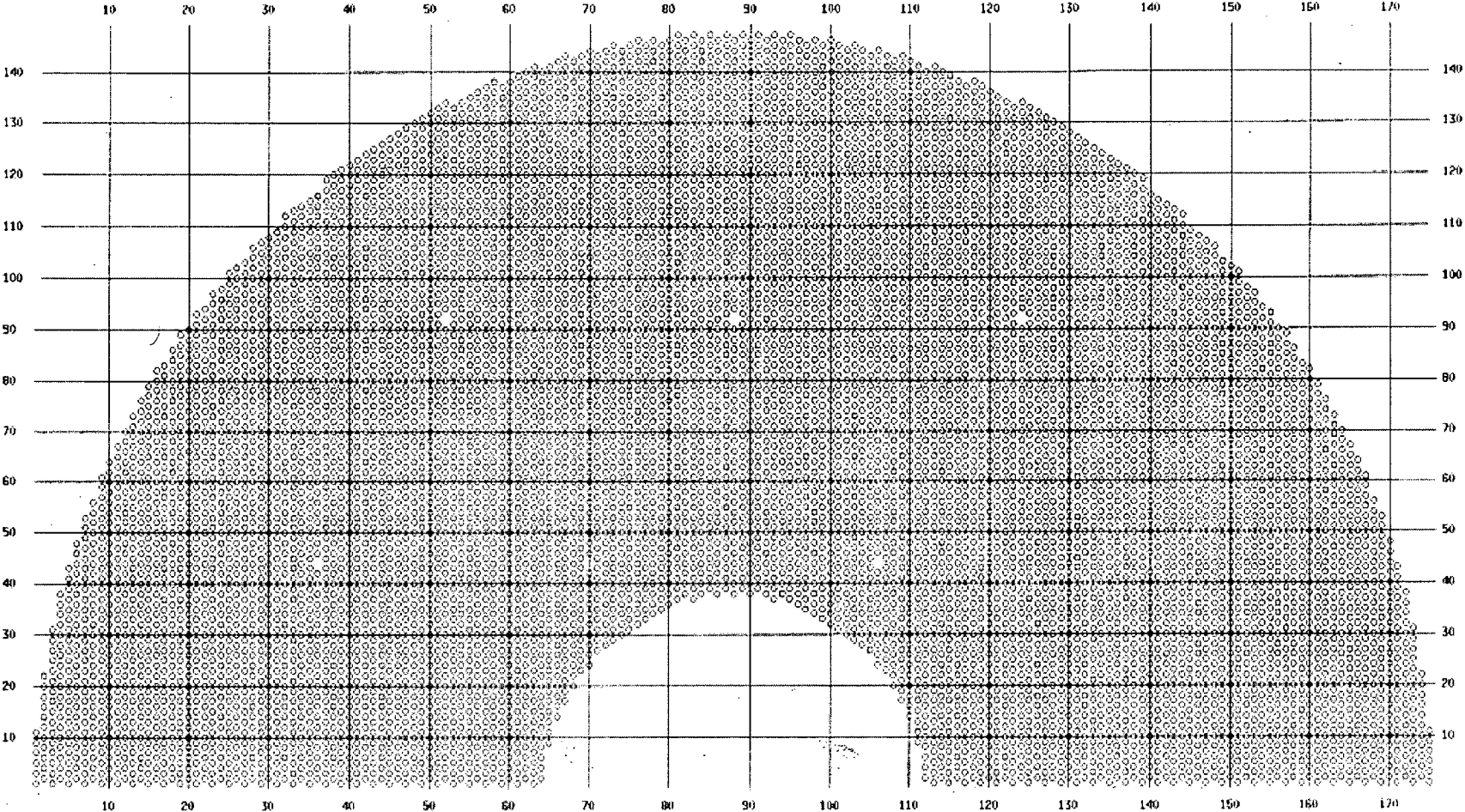

**Appendix 2**

**Legend for Appendices 3 and 4**

**List of Abbreviations and Format Used to Describe Indications from Rotating Probe Testing**

Abbreviations	Explanation of the Abbreviations
SCI	Single Circumferential Indication
MCI	Multiple Circumferential Indications
SAI	Single Axial Indication
MAI	Multiple Axial Indications
MMI	Mixed Mode Indications
SVI	Single Volumetric Indication (i.e. no special axial or circumferential aspect)
MVI	Multiple Volumetric Indications (i.e. no special axial or circumferential aspect)
TWD	Through Wall Depth (an indication of tubing wear used for volumetric wear indicated with a percent value shown in the next column)

**Format**

In Appendices 3 and 4, a single line of data is associated with each individual rotating probe indication. Below is a descriptive example of the format.

ROW	LINE	VOLTS	DEG	CHN	IND	%TW	LOCATION	EXT	EXT	CAL#	LEG	PROBE
4	12	+P VOLTS	+P DEG	CH#	CODE	%	LOCATION	EXT	EXT	#	H/C	TYPE

All "I-Code" indications require a single line entry. The example above displays the form of a Resolution Report line. The VOLTS field contains the Plus Point P-to-P voltage of the largest, most representative response. The DEG field contains the corresponding phase angle. The CHN field contains the reporting channel (i.e. the appropriate 300kHz Plus Point channel). The IND field contains the appropriate 3-letter code (see list above). The %TW field indicates the percent wall loss for wear indications. The LOCATION field contains the abbreviation for the referenced landmark and the distance to the indication. The EXT fields contain the landmarks of the beginning and end of the test extent. The CAL# field identifies the calibration number associated with the acquired data. The LEG field identifies the Hot or Cold Leg as the location of the probe origination. The PROBE field contains the abbreviated identifier of the probe type used for the inspection. For the second column, the terms line and column are used interchangeably for Combustion Engineering designed steam generators.

**Appendix 3**  
**Tube Inspection Summary**  
**Steam Generator E-088**

(de01) Post-U3C15 Inspection Results  
 MAI, MCI, MMI, MVI, SAI, SCI, SVI, TWD

QUERY: de01\_inspection\_results

ROW	COL	VOLTS	DEG	CHN	IND	%TW	LOCATION	EXT	EXT	CAL #	LEG	PROBE	
1	113	0.31	116	P2	TWD	21	04H	+0.77	07H	TEH	45	HOT	600UL
2	40	0.74	22	2	SAI		TSH	-3.87	TSH	TSH	69	HOT	580PP
3	21	0.32	82	P3	TWD	15	DBC	-0.89	DBC	TEC	56	COLD	600UL
7	1	0.36	71	P3	TWD	18	DBC	+0.94	TEC	TEH	35	HOT	600UL
7	175	0.30	151	P2	TWD	15	01C	-0.97	TEH	TEC	51	COLD	600UL
8	42	0.55	26	P1	SCI		TSH	-2.84	TSH	TSH	68	HOT	580PP
8	60	0.19	107	P3	TWD	9	DBH	-0.95	TEC	TEH	41	HOT	600UL
8	134	0.37	94	P3	TWD	20	DBC	-0.96	TEH	TEC	49	COLD	600UL
9	65	0.17	110	P3	TWD	8	DBH	+0.77	TEC	TEH	41	HOT	600UL
11	119	0.46	17	P1	MCI		TSH	-0.11	TSH	TSH	63	HOT	580PP
15	133	0.17	102	P2	TWD	14	07H	-1.01	TEC	TEH	9	HOT	600UL
16	2	0.41	68	P2	TWD	17	05H	-0.59	TEC	TEH	32	HOT	600UL
17	67	0.29	15	P3	TWD	16	DBH	+1.50	TEH	TEC	26	COLD	600UL
17	109	0.25	65	P3	TWD	15	DBC	-2.00	TEH	TEC	45	COLD	600UL
17	173	0.51	115	P2	TWD	21	01C	-0.87	TEC	TEH	42	HOT	600UL
18	132	0.23	117	P3	TWD	17	DBH	+1.99	TEC	TEH	9	HOT	600UL
19	57	0.30	91	P2	TWD	16	07H	-0.97	TEH	TEC	24	COLD	600UL
21	145	0.20	154	P2	TWD	16	VSM	-1.00	TEC	TEH	23	HOT	600UL
22	18	0.24	44	P2	TWD	12	VSM	-0.90	TEC	TEH	26	HOT	600UL
22	24	0.14	118	P3	TWD	8	DBH	+1.71	TEC	TEH	21	HOT	600UL
22	34	0.61	29	P1	SCI		TSH	-0.11	TSH	TSH	65	HOT	580PP
23	13	0.12	114	P2	TWD	6	VSM	-0.95	TEC	TEH	27	HOT	600UL
23	109	0.47	115	P2	TWD	20	07H	+0.04	TEH	TEC	44	COLD	600UL
23	123	0.29	108	P2	TWD	15	07H	+0.36	TEH	TEC	41	COLD	600UL
23	125	0.32	35	P2	TWD	17	07H	-0.38	TEH	TEC	38	COLD	600UL
23	127	0.24	130	P2	TWD	14	06H	+0.35	TEH	TEC	38	COLD	600UL
23	145	0.29	89	P2	TWD	16	VSM	-1.05	TEC	TEH	22	HOT	600UL
23	153	0.28	87	P2	TWD	20	VSM	-0.91	TEC	TEH	31	HOT	600UL
24	20	0.36	95	P2	TWD	17	VSM	-0.78	TEC	TEH	24	HOT	600UL
24	54	0.31	118	P2	TWD	16	07H	+0.84	TEH	TEC	23	COLD	600UL
24	56	0.34	140	P2	TWD	17	07H	-1.18	TEH	TEC	24	COLD	600UL
24	108	0.63	119	P2	TWD	24	VSM	-0.96	TEH	TEC	44	COLD	600UL
24	126	0.27	71	P2	TWD	16	07H	+0.75	TEH	TEC	39	COLD	600UL
25	39	0.30	83	P2	TWD	15	VSM	+1.18	TEC	TEH	13	HOT	600UL
25	167	0.26	50	P2	TWD	10	02H	+0.23	TEC	TEH	38	HOT	600UL
27	67	0.37	137	P2	TWD	18	VSM	+1.02	TEH	TEC	25	COLD	600UL
27	121	0.26	125	P2	TWD	14	07H	+0.11	TEH	TEC	41	COLD	600UL
28	54	0.24	94	P2	TWD	12	06H	+0.15	TEH	TEC	23	COLD	600UL



(de01) Post-U3C15 Inspection Results  
 MAI, MCI, MMI, MVI, SAI, SCI, SVI, TWD

QUERY: de01\_inspection\_results.qry

ROW	COL	VOLTS	DEG	CHN	IND	%TW	LOCATION		EXT	EXT	CAL #	LEG	PROBE
28	172	0.36	57	P2	TWD 24	01C	+0.12		TEC	TEH	43	HOT	600UL
29	13	0.34	82	P3	TWD 14	DBH	+0.98		TEC	TEH	26	HOT	600UL
		0.13	66	P3	TWD 6	DBH	-2.01		TEC	TEH	26	HOT	600UL
29	107	0.27	63	P3	TWD 15	DBH	-1.53		TEH	TEC	45	COLD	600UL
30	172	0.27	33	P2	TWD 13	06H	+0.91		TEC	TEH	42	HOT	600UL
31	39	0.21	89	P2	TWD 10	07H	+0.57		TEC	TEH	12	HOT	600UL
31	55	0.53	33	P2	TWD 23	02H	-1.06		TEH	TEC	23	COLD	600UL
		0.20	121	P1	SCI	TSH	+0.10		TSH	TSH	112	HOT	580PP
31	139	0.40	21	P1	MCI	TSH	-0.18		TSH	TSH	78	HOT	580PP
31	161	0.12	120	P3	TWD 9	DBH	+1.61		TEC	TEH	37	HOT	600UL
31	167	0.18	101	P3	TWD 14	DBH	+0.62		TEC	TEH	39	HOT	600UL
32	42	0.35	135	P2	TWD 15	07H	+0.72		TEC	TEH	10	HOT	600UL
32	60	0.32	148	P2	TWD 16	VSM	-1.10		TEH	TEC	25	COLD	600UL
32	106	0.32	108	P2	TWD 16	04C	+0.88		TEH	TEC	47	COLD	600UL
32	124	0.54	134	P2	TWD 24	VSM	-0.79		TEH	TEC	41	COLD	600UL
32	168	0.21	85	P3	TWD 8	DBH	+0.18		TEC	TEH	38	HOT	600UL
33	43	0.18	67	P2	TWD 9	07H	+0.64		TEC	TEH	10	HOT	600UL
34	56	0.36	160	P2	TWD 17	VSM	-0.74		TEH	TEC	23	COLD	600UL
34	112	0.29	57	P2	TWD 14	VSM	+0.74		TEH	TEC	44	COLD	600UL
34	128	0.20	142	P2	TWD 12	VSM	+0.78		TEH	TEC	38	COLD	600UL
34	172	0.38	66	P2	TWD 17	VSM	+0.87		TEC	TEH	42	HOT	600UL
35	7	0.31	77	P2	TWD 16	VSM	-0.89		TEC	TEH	33	HOT	600UL
35	19	0.22	134	P2	TWD 11	VSM	-0.89		TEC	TEH	25	HOT	600UL
35	47	0.31	156	P2	TWD 16	VSM	+0.82		TEH	TEC	21	COLD	600UL
35	51	0.25	66	P2	TWD 13	07H	-0.60		TEH	TEC	22	COLD	600UL
35	53	0.22	140	P2	TWD 11	VSM	-0.77		TEH	TEC	22	COLD	600UL
35	107	0.25	47	P2	TWD 14	VSM	-0.91		TEH	TEC	46	COLD	600UL
		0.27	159	P2	TWD 15	VSM	+0.14		TEH	TEC	46	COLD	600UL
35	121	0.32	129	P2	TWD 17	05H	+0.79		TEH	TEC	41	COLD	600UL
35	125	0.30	124	P2	TWD 17	VSM	+0.80		TEH	TEC	38	COLD	600UL
		0.19	85	P2	TWD 11	VSM	-0.74		TEH	TEC	38	COLD	600UL
36	46	0.32	137	P2	TWD 16	VSM	+0.71		TEC	TEH	6	HOT	600UL
		0.30	93	P2	TWD 15	VSM	-0.77		TEC	TEH	6	HOT	600UL
		0.20	129	P2	TWD 10	07H	-0.34		TEC	TEH	6	HOT	600UL
36	50	0.31	63	P2	TWD 16	07H	+0.44		TEH	TEC	22	COLD	600UL
		0.27	134	P2	TWD 15	07H	-0.25		TEH	TEC	22	COLD	600UL
		0.27	157	P2	TWD 15	07H	+0.99		TEH	TEC	22	COLD	600UL
36	52	0.32	39	P2	TWD 16	06H	+0.43		TEH	TEC	21	COLD	600UL
36	108	0.54	135	P2	TWD 22	VSM	-0.80		TEH	TEC	44	COLD	600UL
		0.51	135	P2	TWD 21	VSM	-0.19		TEH	TEC	44	COLD	600UL
36	112	0.36	24	2	SAI	TSH	-5.75		TSH	TSH	67	HOT	580PP
		0.37	23	2	SAI	TSH	-3.68		TSH	TSH	67	HOT	580PP
		0.34	28	2	SAI	TSH	-2.82		TSH	TSH	67	HOT	580PP
		0.50	16	2	SAI	TSH	-2.64		TSH	TSH	67	HOT	580PP

(de01) Post-U3C15 Inspection Results  
 MAI, MCI, MMI, MVI, SAI, SCI, SVI, TWD

QUERY: de01\_inspection\_results.qry

ROW	COL	VOLTS	DEG	CHN	IND	%TW	LOCATION	EXT	EXT	CAL #	LEG	PROBE
		0.70	136	P2	TWD 28	VSM	+0.76	TEH	TEC	45	COLD	600UL
		0.25	127	P2	TWD 13	VSM	-0.88	TEH	TEC	45	COLD	600UL
36	162	0.31	122	P2	TWD 16	VSM	+0.84	TEC	TEH	36	HOT	600UL
37	43	0.53	128	P2	TWD 21	VSM	+0.79	TEC	TEH	10	HOT	600UL
37	51	0.32	37	P2	TWD 17	07H	+0.44	TEH	TEC	21	COLD	600UL
37	69	0.28	96	P2	TWD 16	VSM	-0.91	TEH	TEC	26	COLD	600UL
		0.24	145	P2	TWD 15	VSM	+0.88	TEH	TEC	26	COLD	600UL
37	105	0.49	38	P3	TWD 22	DBH	+1.95	TEH	TEC	46	COLD	600UL
37	127	0.27	77	P2	TWD 16	VSM	-0.92	TEH	TEC	39	COLD	600UL
		0.12	95	P2	TWD 7	VSM	+0.82	TEH	TEC	39	COLD	600UL
		0.27	67	P2	TWD 16	VSM	+0.19	TEH	TEC	39	COLD	600UL
37	147	0.20	152	P2	TWD 15	VSM	+0.75	TEC	TEH	29	HOT	600UL
38	104	0.34	76	P3	TWD 15	DBH	-1.61	TEH	TEC	39	COLD	600UL
38	106	0.17	145	P2	TWD 10	VSM	+0.08	TEH	TEC	46	COLD	600UL
		0.24	15	P2	TWD 14	VSM	+0.72	TEH	TEC	46	COLD	600UL
38	112	0.69	18	2	SAI	TSH	-1.31	TSH	TSH	66	HOT	580PP
38	170	0.16	49	P2	TWD 12	01H	-0.12	TEC	TEH	39	HOT	600UL
39	41	0.32	123	P2	TWD 16	VSM	+0.88	TEC	TEH	11	HOT	600UL
		0.31	129	P2	TWD 16	VSM	-0.77	TEC	TEH	11	HOT	600UL
39	55	0.24	130	P2	TWD 13	VSM	-0.76	TEH	TEC	23	COLD	600UL
39	65	0.53	67	P2	TWD 23	VSM	+0.79	TEH	TEC	25	COLD	600UL
39	67	0.51	102	P2	TWD 22	VSM	-0.86	TEH	TEC	25	COLD	600UL
		0.31	148	P2	TWD 15	VSM	+0.85	TEH	TEC	25	COLD	600UL
40	38	0.42	139	P2	TWD 18	VSM	+0.85	TEC	TEH	12	HOT	600UL
		0.21	160	P2	TWD 10	VSM	-0.82	TEC	TEH	12	HOT	600UL
40	54	0.28	69	P2	TWD 15	02H	-1.22	TEH	TEC	23	COLD	600UL
40	62	0.53	115	P2	TWD 23	VSM	+0.81	TEH	TEC	25	COLD	600UL
40	104	0.23	125	P2	TWD 14	VSM	-0.91	TEH	TEC	38	COLD	600UL
		0.12	136	P2	TWD 8	VSM	-0.06	TEH	TEC	38	COLD	600UL
		0.61	154	P2	TWD 27	VSM	+0.78	TEH	TEC	38	COLD	600UL
40	122	0.22	90	P2	TWD 12	07H	-0.40	TEH	TEC	41	COLD	600UL
41	53	0.27	47	P3	TWD 14	DBH	+1.84	TEH	TEC	21	COLD	600UL
41	73	0.31	113	P3	TWD 14	DBH	-1.64	TEH	TEC	27	COLD	600UL
		0.55	168	P3	TWD 22	DBH	+2.10	TEH	TEC	27	COLD	600UL
41	103	0.35	89	P3	TWD 17	DBH	-1.49	TEH	TEC	38	COLD	600UL
		0.51	105	P3	TWD 23	DBH	+2.03	TEH	TEC	38	COLD	600UL
42	36	0.33	115	P2	TWD 15	03C	+0.98	TEC	TEH	12	HOT	600UL
43	5	0.57	115	P2	TWD 21	04C	-0.10	TEC	TEH	32	HOT	600UL
43	9	0.19	139	P2	TWD 11	VSM	-0.82	TEC	TEH	33	HOT	600UL
43	13	0.38	139	P2	TWD 18	VSM	-0.78	TEC	TEH	27	HOT	600UL
43	21	0.35	116	P2	TWD 17	VSM	+0.71	TEC	TEH	25	HOT	600UL
43	53	0.20	155	P2	TWD 11	VSM	-0.85	TEH	TEC	22	COLD	600UL
		0.32	136	P2	TWD 16	VSM	+0.06	TEH	TEC	22	COLD	600UL
		0.55	129	P2	TWD 24	VSM	+0.89	TEH	TEC	22	COLD	600UL
43	115	0.56	143	P2	TWD 24	VSM	+0.97	TEH	TEC	43	COLD	600UL

(de01) Post-U3C15 Inspection Results  
 MAI, MCI, MMI, MVI, SAI, SCI, SVI, TWD

QUERY: de01\_inspection\_results.qry

ROW	COL	VOLTS	DEG	CHN	IND	%TW	LOCATION		EXT	EXT	CAL #	LEG	PROBE
43	123	0.33	98	P2	TWD	17	07H	-0.23	TEH	TEC	41	COLD	600UL
43	149	0.34	49	P2	TWD	16	VSM	+0.86	TEC	TEH	28	HOT	600UL
44	74	0.16	144	P3	TWD	8	DBH	+1.70	TEH	TEC	27	COLD	600UL
		0.32	50	P3	TWD	15	DBH	-1.77	TEH	TEC	27	COLD	600UL
		0.54	15	2	SAI		TSH	-7.27	TSH	TSH	96	HOT	580PP
44	102	0.32	120	P3	TWD	16	DBC	+1.79	TEH	TEC	38	COLD	600UL
44	108	0.85	126	P2	TWD	29	VSM	-0.78	TEH	TEC	44	COLD	600UL
		0.75	109	P2	TWD	27	VSM	-0.21	TEH	TEC	44	COLD	600UL
44	110	0.58	110	P2	TWD	23	VSM	+0.90	TEH	TEC	44	COLD	600UL
		0.22	120	P3	TWD	11	DBC	+1.58	TEH	TEC	44	COLD	600UL
		0.31	113	P2	TWD	14	VSM	-0.27	TEH	TEC	44	COLD	600UL
44	154	0.50	103	P2	TWD	19	VSM	+0.71	TEC	TEH	30	HOT	600UL
45	75	0.31	150	P3	TWD	15	DBC	-1.82	TEH	TEC	27	COLD	600UL
45	101	0.90	30	P3	TWD	31	DBH	+1.62	TEH	TEC	19	COLD	600UL
		0.17	92	P3	TWD	9	DBH	-1.64	TEH	TEC	19	COLD	600UL
		0.29	64	P3	TWD	15	DBC	-1.68	TEH	TEC	19	COLD	600UL
45	169	0.24	73	P2	TWD	10	02C	-0.85	TEC	TEH	38	HOT	600UL
46	76	0.48	65	P3	TWD	25	DBH	-1.88	TEH	TEC	14	COLD	600UL
		0.13	33	P3	TWD	10	DBC	-2.08	TEH	TEC	14	COLD	600UL
46	118	0.15	96	P2	TWD	5	07H	+0.39	TEH	TEC	43	COLD	600UL
47	57	0.18	151	P2	TWD	9	06H	+0.86	TEH	TEC	23	COLD	600UL
47	73	0.49	121	P3	TWD	20	DBC	-1.99	TEH	TEC	27	COLD	600UL
47	75	0.27	88	P3	TWD	13	DBC	-1.65	TEH	TEC	27	COLD	600UL
47	77	0.45	101	P3	TWD	25	DBC	-1.93	TEH	TEC	14	COLD	600UL
47	109	0.34	59	P2	TWD	16	VSM	-0.13	TEH	TEC	44	COLD	600UL
47	111	0.29	159	P2	TWD	14	VSM	-0.80	TEH	TEC	44	COLD	600UL
		0.48	38	P2	TWD	20	VSM	+0.00	TEH	TEC	44	COLD	600UL
47	125	0.28	161	P2	TWD	16	VSM	+0.74	TEH	TEC	38	COLD	600UL
47	137	0.27	75	P2	TWD	19	VSM	+0.11	TEC	TEH	19	HOT	600UL
48	42	0.21	142	P2	TWD	10	07H	-0.70	TEC	TEH	10	HOT	600UL
48	58	0.22	59	P3	TWD	11	DBH	-1.53	TEH	TEC	23	COLD	600UL
48	68	0.51	142	P2	TWD	22	VSM	+0.81	TEH	TEC	25	COLD	600UL
		0.32	91	P2	TWD	16	VSM	-0.89	TEH	TEC	25	COLD	600UL
48	102	0.41	81	P3	TWD	18	DBH	-1.76	TEH	TEC	39	COLD	600UL
48	104	0.49	139	P2	TWD	23	VSM	+0.94	TEH	TEC	46	COLD	600UL
48	106	0.33	82	P2	TWD	18	VSM	-0.73	TEH	TEC	46	COLD	600UL
		0.48	66	P2	TWD	23	VSM	-0.06	TEH	TEC	46	COLD	600UL
		0.48	92	P2	TWD	23	VSM	+0.86	TEH	TEC	46	COLD	600UL
48	108	0.51	117	P2	TWD	21	VSM	-0.27	TEH	TEC	44	COLD	600UL
48	126	0.53	130	P2	TWD	26	VSM	+0.80	TEH	TEC	39	COLD	600UL
48	152	0.60	103	P2	TWD	21	VSM	-0.66	TEC	TEH	30	HOT	600UL
48	154	0.44	126	P2	TWD	17	VSM	+0.84	TEC	TEH	30	HOT	600UL
		0.19	38	P2	TWD	8	VSM	-0.12	TEC	TEH	30	HOT	600UL
49	7	0.25	100	P2	TWD	11	06H	-1.19	TEC	TEH	32	HOT	600UL
49	41	0.70	116	P2	TWD	25	08H	+1.53	TEC	TEH	10	HOT	600UL

(de01) Post-U3C15 Inspection Results  
 MAI, MCI, MMI, MVI, SAI, SCI, SVI, TWD

QUERY: de01\_inspection\_results.qry

ROW	COL	VOLTS	DEG	CHN	IND	%TW	LOCATION	EXT	EXT	CAL #	LEG	PROBE	
49	43	0.30	101	P2	TWD	14	08H	+1.89	TEC	TEH	10	HOT	600UL
		0.45	94	P2	TWD	19	08H	-1.65	TEC	TEH	10	HOT	600UL
49	49	0.18	137	P2	TWD	10	08H	-1.27	TEH	TEC	21	COLD	600UL
		0.31	124	P2	TWD	16	08H	+1.52	TEH	TEC	21	COLD	600UL
49	75	0.25	5	P3	TWD	11	DBC	-1.41	TEH	TEC	27	COLD	600UL
49	77	0.23	59	P2	TWD	11	06H	-0.90	TEH	TEC	13	COLD	600UL
49	101	0.54	74	P3	TWD	26	DBH	-1.66	TEH	TEC	20	COLD	600UL
49	115	0.54	131	P2	TWD	23	08H	+1.48	TEH	TEC	42	COLD	600UL
49	125	0.32	123	P2	TWD	16	08H	-1.27	TEH	TEC	41	COLD	600UL
		0.41	74	P2	TWD	20	08H	+1.59	TEH	TEC	41	COLD	600UL
49	131	0.25	33	P3	TWD	10	DBH	-0.99	TEC	TEH	8	HOT	600UL
49	169	0.48	74	P2	TWD	18	01C	-0.85	TEC	TEH	38	HOT	600UL
50	48	0.17	63	P2	TWD	10	08H	+1.45	TEH	TEC	22	COLD	600UL
51	17	0.22	157	P2	TWD	11	VH3	+0.64	TEC	TEH	27	HOT	600UL
51	79	0.25	111	P3	TWD	16	DBC	-1.79	TEH	TEC	14	COLD	600UL
51	83	0.41	87	P3	TWD	19	DBH	-1.56	TEH	TEC	19	COLD	600UL
		0.81	86	P3	TWD	29	DBC	-1.68	TEH	TEC	19	COLD	600UL
51	99	0.42	14	P3	TWD	23	DBH	+1.83	TEH	TEC	20	COLD	600UL
		0.41	46	P3	TWD	23	DBH	-2.00	TEH	TEC	20	COLD	600UL
52	168	0.26	118	P2	TWD	10	01H	+0.06	TEC	TEH	38	HOT	600UL
		0.49	126	P2	TWD	18	01C	-0.16	TEC	TEH	38	HOT	600UL
53	35	0.57	108	P2	TWD	23	VH3	+0.68	TEC	TEH	12	HOT	600UL
53	37	0.44	151	P2	TWD	20	VH3	+0.69	TEC	TEH	13	HOT	600UL
53	81	0.32	92	P3	TWD	18	DBH	+1.69	TEH	TEC	16	COLD	600UL
		0.31	135	P3	TWD	18	DBC	+2.00	TEH	TEC	16	COLD	600UL
53	87	0.30	134	P3	TWD	15	DBH	-1.68	TEH	TEC	19	COLD	600UL
53	95	0.36	53	P3	TWD	21	DBC	-1.62	TEH	TEC	20	COLD	600UL
53	145	0.19	108	P2	TWD	16	VH3	+0.49	TEC	TEH	23	HOT	600UL
54	84	0.28	97	P3	TWD	14	DBC	-1.68	TEH	TEC	19	COLD	600UL
54	88	0.37	34	P3	TWD	21	DBH	-1.64	TEH	TEC	20	COLD	600UL
		0.38	8	P3	TWD	21	DBH	+1.83	TEH	TEC	20	COLD	600UL
55	81	0.40	106	P3	TWD	18	DBH	+1.76	TEH	TEC	15	COLD	600UL
55	99	0.43	72	P3	TWD	23	DBH	-1.68	TEH	TEC	20	COLD	600UL
56	38	0.58	126	P2	TWD	23	VH3	-0.89	TEC	TEH	12	HOT	600UL
56	44	0.48	52	P2	TWD	20	08H	+0.83	TEC	TEH	10	HOT	600UL
56	46	0.53	125	P2	TWD	23	08H	+0.56	TEC	TEH	6	HOT	600UL
56	96	0.34	41	P3	TWD	20	DBC	+1.54	TEH	TEC	20	COLD	600UL
56	98	0.71	124	P3	TWD	27	DBH	-1.60	TEH	TEC	19	COLD	600UL
56	166	0.53	122	P2	TWD	20	01C	-0.83	TEC	TEH	38	HOT	600UL
57	79	0.39	102	P2	TWD	19	08H	-0.98	TEH	TEC	13	COLD	600UL
		0.33	98	P3	TWD	15	DBC	-1.85	TEH	TEC	13	COLD	600UL
57	83	0.25	70	P3	TWD	13	DBC	-1.89	TEH	TEC	19	COLD	600UL
		0.17	40	P3	TWD	9	DBC	+1.56	TEH	TEC	19	COLD	600UL

(de01) Post-U3C15 Inspection Results  
 MAI, MCI, MMI, MVI, SAI, SCI, SVI, TWD

QUERY: de01\_inspection\_results.qry

ROW	COL	VOLTS	DEG	CHN	IND	%TW	LOCATION		EXT	EXT	CAL #	LEG	PROBE
57	85	0.45	39	P3	TWD	20	DBH	+1.68	TEH	TEC	19	COLD	600UL
57	91	0.73	127	P3	TWD	27	DBH	-1.43	TEH	TEC	19	COLD	600UL
		0.53	45	P3	TWD	23	DBC	+1.68	TEH	TEC	19	COLD	600UL
		0.37	148	P3	TWD	17	DBC	-1.85	TEH	TEC	19	COLD	600UL
57	167	0.26	144	P2	TWD	10	01H	+0.10	TEC	TEH	38	HOT	600UL
58	44	0.34	94	P2	TWD	17	08H	-0.47	TEC	TEH	11	HOT	600UL
58	50	0.19	81	P2	TWD	10	VH3	+0.97	TEH	TEC	22	COLD	600UL
58	88	0.28	30	P3	TWD	17	DBH	-1.49	TEH	TEC	20	COLD	600UL
58	90	0.36	68	P3	TWD	17	DBH	-1.49	TEH	TEC	19	COLD	600UL
		0.24	19	P3	TWD	12	DBC	+1.75	TEH	TEC	19	COLD	600UL
58	92	0.29	44	P3	TWD	17	DBH	-1.71	TEH	TEC	20	COLD	600UL
58	96	0.15	77	P3	TWD	8	DBH	-1.55	TEH	TEC	19	COLD	600UL
		0.21	44	P3	TWD	11	DBC	+1.47	TEH	TEC	19	COLD	600UL
58	98	0.23	23	P3	TWD	15	DBH	-1.66	TEH	TEC	20	COLD	600UL
59	93	0.52	80	P3	TWD	22	DBH	-1.55	TEH	TEC	19	COLD	600UL
59	99	0.22	130	P3	TWD	12	DBH	-1.43	TEH	TEC	19	COLD	600UL
59	123	0.24	62	P2	TWD	13	07H	-0.38	TEH	TEC	41	COLD	600UL
60	30	0.60	111	P2	TWD	23	VH3	-0.82	TEC	TEH	16	HOT	600UL
60	84	0.31	89	P3	TWD	14	DBH	+1.39	TEH	TEC	19	COLD	600UL
60	92	0.37	14	P3	TWD	18	DBH	+1.94	TEH	TEC	19	COLD	600UL
60	98	0.38	14	P3	TWD	18	DBH	+1.91	TEH	TEC	19	COLD	600UL
60	128	0.32	51	P2	TWD	18	08H	+0.32	TEH	TEC	39	COLD	600UL
61	47	0.24	135	P2	TWD	13	08H	+0.57	TEH	TEC	21	COLD	600UL
		0.18	98	P2	TWD	10	03C	-1.03	TEH	TEC	21	COLD	600UL
61	77	0.35	41	P2	TWD	18	08H	-0.92	TEH	TEC	37	COLD	600UL
61	79	0.61	86	P2	TWD	25	VSM	+0.78	TEH	TEC	13	COLD	600UL
61	81	0.29	11	P3	TWD	17	DBH	+1.36	TEH	TEC	16	COLD	600UL
61	83	0.48	126	P3	TWD	23	DBC	+1.58	TEH	TEC	18	COLD	600UL
61	85	0.56	28	P3	TWD	23	DBH	+1.72	TEH	TEC	19	COLD	600UL
61	129	0.43	92	P2	TWD	21	08H	+0.47	TEH	TEC	38	COLD	600UL
61	141	0.36	89	P2	TWD	19	VSM	-0.95	TEC	TEH	22	HOT	600UL
62	82	0.46	119	P3	TWD	22	DBH	-1.53	TEH	TEC	18	COLD	600UL
62	88	0.26	89	P3	TWD	15	DBH	-1.20	TEH	TEC	18	COLD	600UL
62	166	0.21	64	P2	TWD	15	01H	+0.16	TEC	TEH	39	HOT	600UL
63	35	0.25	29	P3	TWD	13	DBH	-1.66	TEC	TEH	13	HOT	600UL
63	83	0.37	89	P3	TWD	17	DBC	+1.60	TEH	TEC	17	COLD	600UL
63	89	0.40	104	P3	TWD	19	DBC	+1.63	TEH	TEC	19	COLD	600UL
63	91	0.27	154	P3	TWD	14	DBC	-1.70	TEH	TEC	17	COLD	600UL
64	52	0.23	85	P2	TWD	12	05C	+0.87	TEH	TEC	21	COLD	600UL
64	54	0.26	45	P2	TWD	14	08H	-0.35	TEH	TEC	23	COLD	600UL

(de01) Post-U3C15 Inspection Results  
 MAI, MCI, MMI, MVI, SAI, SCI, SVI, TWD

QUERY: de01\_inspection\_results.qry

ROW	COL	VOLTS	DEG	CHN	IND	%TW	LOCATION		EXT	EXT	CAL #	LEG	PROBE
64	78	0.27	106	P2	TWD 13	08H	+0.02		TEH	TEC	13	COLD	600UL
64	128	0.30	128	P2	TWD 17	08H	+0.40		TEH	TEC	39	COLD	600UL
64	148	0.38	89	P2	TWD 18	VH3	-0.87		TEC	TEH	28	HOT	600UL
65	77	0.24	45	P3	TWD 12	DBH	-0.61		TEH	TEC	37	COLD	600UL
65	85	0.36	17	P3	TWD 18	DBH	+1.71		TEH	TEC	18	COLD	600UL
65	91	0.17	37	P3	TWD 9	DBC	-1.69		TEH	TEC	18	COLD	600UL
65	165	0.54	121	P2	TWD 20	01C	-0.81		TEC	TEH	38	HOT	600UL
66	14	0.25	109	P2	TWD 13	04C	-0.16		TEC	TEH	27	HOT	600UL
66	40	0.17	100	P3	TWD 9	DBC	+1.97		TEC	TEH	11	HOT	600UL
66	74	0.28	118	P3	TWD 18	DBH	+1.87		TEH	TEC	28	COLD	600UL
66	78	0.27	82	P2	TWD 15	02H	-0.27		TEH	TEC	14	COLD	600UL
66	80	0.17	145	P3	TWD 12	DBH	-2.03		TEH	TEC	14	COLD	600UL
67	45	0.16	118	P2	TWD 9	08H	+0.34		TEC	TEH	11	HOT	600UL
67	63	0.21	47	P2	TWD 11	VSM	-0.89		TEH	TEC	25	COLD	600UL
67	143	0.48	98	P2	TWD 23	VH3	+0.78		TEC	TEH	22	HOT	600UL
		0.31	33	P2	TWD 17	VC3	+0.84		TEC	TEH	22	HOT	600UL
68	56	0.23	101	P2	TWD 12	05C	-0.90		TEH	TEC	23	COLD	600UL
68	68	0.27	92	P2	TWD 14	VC3	+0.28		TEH	TEC	25	COLD	600UL
68	88	0.34	142	P3	TWD 16	DBH	-1.61		TEH	TEC	17	COLD	600UL
69	59	0.12	48	P3	TWD 7	DBC	+1.82		TEH	TEC	24	COLD	600UL
69	77	0.39	71	P3	TWD 18	DBH	+1.99		TEH	TEC	37	COLD	600UL
70	50	0.29	117	P2	TWD 15	08H	-1.08		TEH	TEC	22	COLD	600UL
70	114	0.27	135	P2	TWD 12	07H	-0.79		TEH	TEC	43	COLD	600UL
70	138	0.29	119	P2	TWD 20	VC3	-0.93		TEC	TEH	19	HOT	600UL
70	162	0.22	159	P2	TWD 17	08H	+0.80		TEC	TEH	37	HOT	600UL
70	164	0.41	49	P2	TWD 16	08H	+1.03		TEC	TEH	38	HOT	600UL
71	23	0.20	42	P3	TWD 11	DBH	+1.68		TEC	TEH	25	HOT	600UL
71	89	0.51	52	P3	TWD 22	DBC	-1.70		TEH	TEC	17	COLD	600UL
72	14	0.39	88	P3	TWD 16	DBC	-1.65		TEC	TEH	26	HOT	600UL
72	34	0.50	122	P2	TWD 20	VSM	-0.89		TEC	TEH	12	HOT	600UL
72	36	0.17	84	P2	TWD 8	VH3	-0.29		TEC	TEH	12	HOT	600UL
72	42	0.41	140	P2	TWD 18	VH3	+0.64		TEC	TEH	10	HOT	600UL
		0.35	101	P2	TWD 15	VH3	+0.06		TEC	TEH	10	HOT	600UL
		0.32	100	P2	TWD 14	VH3	-0.49		TEC	TEH	10	HOT	600UL
		0.23	157	P2	TWD 11	VSM	-0.87		TEC	TEH	10	HOT	600UL
72	44	0.29	60	P3	TWD 12	DBC	+2.11		TEC	TEH	10	HOT	600UL
72	58	0.35	124	P2	TWD 17	08H	+0.66		TEH	TEC	23	COLD	600UL
72	90	0.24	103	P3	TWD 12	DBC	+1.50		TEH	TEC	17	COLD	600UL
72	148	0.25	106	P2	TWD 13	VC3	+0.93		TEC	TEH	28	HOT	600UL
		0.23	27	P2	TWD 11	VH3	+0.93		TEC	TEH	28	HOT	600UL
73	31	0.39	75	P2	TWD 18	VH3	+0.88		TEC	TEH	17	HOT	600UL

(de01) Post-U3C15 Inspection Results  
 MAI, MCI, MMI, MVI, SAI, SCI, SVI, TWD

QUERY: de01\_inspection\_results.qry

ROW	COL	VOLTS	DEG	CHN	IND	%TW	LOCATION		EXT	EXT	CAL #	LEG	PROBE
73	33	0.27	152	P2	TWD 12		VH3	+0.74	TEC	TEH	16	HOT	600UL
		0.45	97	P3	TWD 18		DBH	+1.96	TEC	TEH	16	HOT	600UL
73	39	0.28	146	P2	TWD 14		VC3	+0.88	TEC	TEH	13	HOT	600UL
73	45	0.46	78	P2	TWD 19		VC3	+0.19	TEC	TEH	10	HOT	600UL
73	51	0.35	121	P2	TWD 18		VSM	+0.74	TEH	TEC	21	COLD	600UL
		0.31	144	P2	TWD 16		VC3	+0.76	TEH	TEC	21	COLD	600UL
		0.40	100	P2	TWD 19		VC3	+0.21	TEH	TEC	21	COLD	600UL
		0.21	29	P2	TWD 11		VSM	+0.19	TEH	TEC	21	COLD	600UL
		0.27	126	P2	TWD 14		VSM	-0.88	TEH	TEC	21	COLD	600UL
		0.32	146	P2	TWD 16		VH3	+0.74	TEH	TEC	21	COLD	600UL
		0.27	91	P2	TWD 14		VH3	+0.21	TEH	TEC	21	COLD	600UL
73	53	0.23	136	P2	TWD 12		VH3	-0.87	TEH	TEC	21	COLD	600UL
		0.37	123	P2	TWD 18		VC3	+0.21	TEH	TEC	21	COLD	600UL
		0.50	124	P2	TWD 23		VC3	+0.79	TEH	TEC	21	COLD	600UL
		0.33	66	P2	TWD 17		VH3	-0.06	TEH	TEC	21	COLD	600UL
73	55	0.21	154	P2	TWD 11		VH3	+0.88	TEH	TEC	24	COLD	600UL
73	61	0.17	127	P2	TWD 9		VH3	-0.85	TEH	TEC	25	COLD	600UL
		0.46	119	P2	TWD 21		VSM	+0.81	TEH	TEC	25	COLD	600UL
		0.34	157	P2	TWD 16		VC3	-0.81	TEH	TEC	25	COLD	600UL
		0.18	105	P2	TWD 10		VC3	+0.21	TEH	TEC	25	COLD	600UL
73	65	0.34	111	P2	TWD 19		VH3	-0.76	TEH	TEC	26	COLD	600UL
		0.20	158	P2	TWD 12		VH3	+0.87	TEH	TEC	26	COLD	600UL
		0.18	53	P2	TWD 11		VSM	-0.97	TEH	TEC	26	COLD	600UL
73	73	0.29	38	P2	TWD 14		VSM	+0.86	TEH	TEC	28	COLD	600UL
		0.36	144	P2	TWD 17		VC3	-0.72	TEH	TEC	28	COLD	600UL
73	85	0.18	107	P3	TWD 11		DBC	+2.02	TEH	TEC	18	COLD	600UL
73	89	0.19	156	P3	TWD 10		DBH	+1.56	TEH	TEC	18	COLD	600UL
73	107	0.27	126	P2	TWD 14		VH3	-0.84	TEH	TEC	47	COLD	600UL
		0.77	124	P2	TWD 29		VH3	+0.76	TEH	TEC	47	COLD	600UL
73	111	0.24	134	P2	TWD 12		VSM	-0.66	TEH	TEC	44	COLD	600UL
		0.39	148	P2	TWD 17		VSM	+0.78	TEH	TEC	44	COLD	600UL
73	113	0.37	73	P2	TWD 17		02H	-1.22	TEH	TEC	42	COLD	600UL
74	20	0.33	174	P3	TWD 16		DBH	+1.53	TEC	TEH	25	HOT	600UL
74	32	0.39	23	P3	TWD 19		DBH	+1.65	TEC	TEH	17	HOT	600UL
74	34	0.35	58	P3	TWD 16		DBH	+1.67	TEC	TEH	13	HOT	600UL
74	38	0.22	136	P3	TWD 11		DBH	+1.52	TEC	TEH	13	HOT	600UL
74	62	0.17	47	P3	TWD 11		DBH	+2.17	TEH	TEC	26	COLD	600UL
74	84	0.35	136	P3	TWD 18		DBC	-1.44	TEH	TEC	18	COLD	600UL
74	94	0.30	120	P3	TWD 16		DBH	-1.69	TEH	TEC	18	COLD	600UL
74	118	0.43	96	P2	TWD 21		08H	+0.88	TEH	TEC	41	COLD	600UL
74	160	0.37	101	P2	TWD 24		08C	-0.21	TEC	TEH	37	HOT	600UL
75	15	0.17	5	P3	TWD 9		DBC	+1.88	TEC	TEH	27	HOT	600UL
75	31	0.25	4	P3	TWD 10		DBC	+1.65	TEC	TEH	16	HOT	600UL
		0.30	128	P2	TWD 13		VH3	+0.80	TEC	TEH	16	HOT	600UL
		0.14	69	P3	TWD 6		DBH	-1.56	TEC	TEH	16	HOT	600UL
75	33	0.31	89	P3	TWD 16		DBC	-1.56	TEC	TEH	17	HOT	600UL
		0.26	127	P2	TWD 13		VC3	+0.86	TEC	TEH	17	HOT	600UL
75	35	0.09	114	P3	TWD 4		DBC	-1.48	TEC	TEH	13	HOT	600UL

(de01) Post-U3C15 Inspection Results  
MAI, MCI, MMI, MVI, SAI, SCI, SVI, TWD

QUERY: de01\_inspection\_results.qry

ROW	COL	VOLTS	DEG	CHN	IND	%TW	LOCATION	EXT	EXT	CAL #	LEG	PROBE
75	37	0.12	140	P3	TWD 5	DBC	+2.01	TEC	TEH	12	HOT	600UL
75	45	0.37	107	P2	TWD 18	VSM	+0.88	TEC	TEH	11	HOT	600UL
		0.38	130	P2	TWD 18	VH3	+0.73	TEC	TEH	11	HOT	600UL
		0.26	84	P2	TWD 13	VH3	+0.09	TEC	TEH	11	HOT	600UL
		0.29	117	P2	TWD 15	VH3	-0.83	TEC	TEH	11	HOT	600UL
75	47	0.22	87	P2	TWD 12	VH3	+0.13	TEH	TEC	21	COLD	600UL
		0.36	136	P2	TWD 18	VC3	+0.76	TEH	TEC	21	COLD	600UL
		0.19	151	P3	TWD 10	DBC	+1.64	TEH	TEC	21	COLD	600UL
75	75	0.33	148	P2	TWD 16	VSM	+0.85	TEH	TEC	27	COLD	600UL
		0.54	136	P2	TWD 23	VSM	-0.91	TEH	TEC	27	COLD	600UL
75	85	0.23	50	P3	TWD 12	DBC	-1.97	TEH	TEC	17	COLD	600UL
75	121	0.15	113	P2	TWD 9	VH3	-0.86	TEH	TEC	41	COLD	600UL
76	18	0.58	151	P2	TWD 23	VH3	+0.88	TEC	TEH	24	HOT	600UL
76	28	0.16	32	P3	TWD 6	DBC	+2.12	TEC	TEH	20	HOT	600UL
76	32	0.46	50	P3	TWD 18	DBH	+1.89	TEC	TEH	16	HOT	600UL
76	34	0.12	177	P3	TWD 6	DBC	+2.13	TEC	TEH	12	HOT	600UL
		0.52	106	P2	TWD 22	VH3	+0.85	TEC	TEH	12	HOT	600UL
		0.17	139	P3	TWD 8	DBH	+1.44	TEC	TEH	12	HOT	600UL
76	36	0.44	130	P2	TWD 19	VH3	-0.19	TEC	TEH	12	HOT	600UL
		0.62	114	P2	TWD 24	VH3	-0.70	TEC	TEH	12	HOT	600UL
		0.33	131	P3	TWD 14	DBC	+2.19	TEC	TEH	12	HOT	600UL
		0.18	7	P3	TWD 8	DBH	+1.65	TEC	TEH	12	HOT	600UL
76	40	0.39	77	P2	TWD 17	VH3	+0.72	TEC	TEH	10	HOT	600UL
		0.19	84	P3	TWD 9	DBC	+1.78	TEC	TEH	10	HOT	600UL
76	48	0.28	30	P2	TWD 15	VH3	-0.11	TEH	TEC	21	COLD	600UL
		0.51	133	P2	TWD 23	VSM	-0.90	TEH	TEC	21	COLD	600UL
		0.42	148	P2	TWD 20	VSM	+0.90	TEH	TEC	21	COLD	600UL
		0.13	143	P2	TWD 8	VC3	-0.76	TEH	TEC	21	COLD	600UL
		0.29	50	P2	TWD 15	VC3	+0.93	TEH	TEC	21	COLD	600UL
		0.26	121	P2	TWD 14	VH3	+0.78	TEH	TEC	21	COLD	600UL
76	52	0.27	148	P2	TWD 14	VH3	-0.80	TEH	TEC	21	COLD	600UL
76	56	0.21	137	P2	TWD 11	05C	+0.83	TEH	TEC	23	COLD	600UL
		0.24	127	P2	TWD 12	04C	+0.84	TEH	TEC	23	COLD	600UL
		0.17	126	P2	TWD 9	03C	+0.97	TEH	TEC	23	COLD	600UL
76	58	0.13	130	P3	TWD 7	DBC	-1.69	TEH	TEC	23	COLD	600UL
76	62	0.29	126	P2	TWD 15	04C	+0.89	TEH	TEC	25	COLD	600UL
76	68	0.41	71	P2	TWD 19	07H	+0.99	TEH	TEC	25	COLD	600UL
76	72	0.21	71	P2	TWD 11	VH3	-0.91	TEH	TEC	28	COLD	600UL
76	90	0.26	47	P2	TWD 14	08C	-0.17	TEH	TEC	17	COLD	600UL
76	114	0.32	133	P2	TWD 16	VSM	-0.72	TEH	TEC	42	COLD	600UL
		0.54	116	P2	TWD 23	VH3	+0.57	TEH	TEC	42	COLD	600UL
		0.37	134	P2	TWD 18	VC3	+0.82	TEH	TEC	42	COLD	600UL
76	132	0.32	97	P2	TWD 16	VH3	+0.77	TEC	TEH	8	HOT	600UL
		0.19	123	P3	TWD 8	DBC	-1.80	TEC	TEH	8	HOT	600UL
		0.30	99	P2	TWD 15	VH3	-0.81	TEC	TEH	8	HOT	600UL
76	134	0.15	26	P3	TWD 6	DBC	+2.15	TEC	TEH	14	HOT	600UL
76	136	0.33	92	P2	TWD 15	VSM	-0.83	TEC	TEH	18	HOT	600UL
		0.61	116	P2	TWD 24	VH3	+0.95	TEC	TEH	18	HOT	600UL
77	15	0.32	87	P3	TWD 14	DBC	-1.88	TEC	TEH	26	HOT	600UL
77	27	0.31	13	P3	TWD 13	DBC	+2.18	TEC	TEH	20	HOT	600UL



(de01) Post-U3C15 Inspection Results  
 MAI, MCI, MMI, MVI, SAI, SCI, SVI, TWD

QUERY: de01\_inspection\_results:qry

ROW	COL	VOLTS	DEG	CHN	IND	%TW	LOCATION		EXT	EXT	CAL #	LEG	PROBE
77	29	0.29	152	P2	TWD	13	VC3	-0.84	TEC	TEH	20	HOT	600UL
		0.29	90	P3	TWD	12	DBC	-1.81	TEC	TEH	20	HOT	600UL
77	31	0.31	126	P2	TWD	15	VC3	+0.88	TEC	TEH	17	HOT	600UL
		0.56	126	P2	TWD	23	VSM	+0.84	TEC	TEH	17	HOT	600UL
		0.44	127	P3	TWD	20	DBH	+1.96	TEC	TEH	17	HOT	600UL
77	57	0.52	71	P2	TWD	23	VC3	+1.06	TEH	TEC	23	COLD	600UL
		0.35	105	P2	TWD	17	VC3	+0.21	TEH	TEC	23	COLD	600UL
77	73	0.27	133	P2	TWD	13	VH3	+0.85	TEH	TEC	28	COLD	600UL
77	113	0.09	139	P3	TWD	4	DBC	+1.80	TEH	TEC	42	COLD	600UL
		0.24	144	P2	TWD	12	VH3	-0.86	TEH	TEC	42	COLD	600UL
		0.43	83	P2	TWD	20	VH3	+0.74	TEH	TEC	42	COLD	600UL
		0.24	93	P2	TWD	12	VSM	-0.04	TEH	TEC	42	COLD	600UL
		0.26	54	P2	TWD	13	VSM	+0.82	TEH	TEC	42	COLD	600UL
		0.19	144	P2	TWD	10	VC3	-0.90	TEH	TEC	42	COLD	600UL
77	131	0.34	92	P2	TWD	16	VH3	-0.93	TEC	TEH	8	HOT	600UL
77	161	0.24	37	P2	TWD	13	07C	-0.93	TEC	TEH	36	HOT	600UL
		0.26	27	P3	TWD	11	DBH	+1.75	TEC	TEH	36	HOT	600UL
		0.17	160	P2	TWD	10	08C	-0.93	TEC	TEH	36	HOT	600UL
78	20	0.38	60	P3	TWD	18	DBH	+1.71	TEC	TEH	25	HOT	600UL
78	38	0.24	126	P2	TWD	13	VH3	-0.89	TEC	TEH	13	HOT	600UL
		0.23	58	P3	TWD	11	DBH	+1.39	TEC	TEH	13	HOT	600UL
78	102	0.39	16	P3	TWD	19	DBH	+1.94	TEH	TEC	38	COLD	600UL
78	124	0.36	100	P2	TWD	18	VC3	-0.83	TEH	TEC	41	COLD	600UL
		0.58	85	P2	TWD	26	VH3	+0.83	TEH	TEC	41	COLD	600UL
		0.40	120	P2	TWD	20	VH3	+0.06	TEH	TEC	41	COLD	600UL
		0.54	110	P2	TWD	24	VC3	+0.95	TEH	TEC	41	COLD	600UL
79	21	0.24	52	P3	TWD	11	DBC	+1.57	TEC	TEH	24	HOT	600UL
		0.62	110	P3	TWD	23	DBH	+1.60	TEC	TEH	24	HOT	600UL
79	29	0.32	103	P2	TWD	14	VC3	-0.93	TEC	TEH	20	HOT	600UL
		0.11	172	P3	TWD	4	DBH	+1.73	TEC	TEH	20	HOT	600UL
79	47	0.24	116	P2	TWD	13	VC3	-0.90	TEH	TEC	21	COLD	600UL
79	55	0.13	169	P3	TWD	6	DBH	+1.78	TEH	TEC	23	COLD	600UL
79	59	0.35	147	P3	TWD	16	DBH	+1.95	TEH	TEC	23	COLD	600UL
79	89	0.30	149	P3	TWD	15	DBH	+1.50	TEH	TEC	17	COLD	600UL
		0.51	133	P2	TWD	23	VH3	+0.91	TEH	TEC	17	COLD	600UL
79	115	0.37	148	P2	TWD	17	VH3	+0.76	TEH	TEC	42	COLD	600UL
		0.31	131	P2	TWD	15	VSM	-0.16	TEH	TEC	42	COLD	600UL
		0.37	58	P2	TWD	17	VC3	-0.90	TEH	TEC	42	COLD	600UL
79	117	0.25	114	P2	TWD	13	07H	-0.83	TEH	TEC	42	COLD	600UL
		0.67	99	P2	TWD	26	VC3	-0.97	TEH	TEC	42	COLD	600UL
		0.72	116	P2	TWD	28	VC3	+0.80	TEH	TEC	42	COLD	600UL
79	125	0.33	136	P2	TWD	18	VC3	-0.86	TEH	TEC	40	COLD	600UL
		0.38	123	P2	TWD	19	VC3	+0.86	TEH	TEC	40	COLD	600UL
79	131	0.24	88	P2	TWD	12	VSM	-0.58	TEC	TEH	8	HOT	600UL
79	161	0.44	97	P2	TWD	21	08H	-0.16	TEC	TEH	36	HOT	600UL
		0.28	55	P3	TWD	12	DBH	+1.58	TEC	TEH	36	HOT	600UL
80	22	0.25	60	P3	TWD	10	DBH	+2.13	TEC	TEH	24	HOT	600UL
80	38	0.21	90	P2	TWD	10	VC3	+0.76	TEC	TEH	12	HOT	600UL
		0.34	128	P2	TWD	16	VC3	-0.93	TEC	TEH	12	HOT	600UL
		0.79	121	P2	TWD	28	VSM	+0.76	TEC	TEH	12	HOT	600UL
		0.99	136	P2	TWD	32	VH3	-0.91	TEC	TEH	12	HOT	600UL
		0.57	125	P3	TWD	21	DBH	+1.53	TEC	TEH	12	HOT	600UL

(de01) Post-U3C15 Inspection Results  
 MAI, MCI, MMI, MVI, SAI, SCI, SVI, TWD

QUERY: de01\_inspection\_results.qry

ROW	COL	VOLTS	DEG	CHN	IND	%TW	LOCATION	EXT	EXT	CAL #	LEG	PROBE
80	40	0.20	124	P3	TWD 9	DBC	+1.49	TEC	TEH	10	HOT	600UL
		0.29	94	P2	TWD 13	VC3	-0.08	TEC	TEH	10	HOT	600UL
		0.23	86	P2	TWD 11	VC3	+0.66	TEC	TEH	10	HOT	600UL
		0.18	160	P2	TWD 9	VH3	+0.64	TEC	TEH	10	HOT	600UL
		0.42	86	P2	TWD 18	VH3	+0.02	TEC	TEH	10	HOT	600UL
80	80	0.67	77	P2	TWD 27	VSM	+0.95	TEH	TEC	17	COLD	600UL
		0.40	71	P2	TWD 19	VH3	+0.59	TEH	TEC	17	COLD	600UL
80	102	0.61	86	P2	TWD 27	VC3	-0.91	TEH	TEC	38	COLD	600UL
80	132	0.13	176	P3	TWD 6	DBC	+1.66	TEC	TEH	8	HOT	600UL
80	142	0.58	111	P2	TWD 26	VC3	+0.72	TEC	TEH	22	HOT	600UL
		0.47	143	P2	TWD 23	VC3	-0.88	TEC	TEH	22	HOT	600UL
		0.28	123	P2	TWD 15	VSM	+0.80	TEC	TEH	22	HOT	600UL
		0.37	134	P2	TWD 19	VSM	-0.80	TEC	TEH	22	HOT	600UL
		0.48	128	P2	TWD 23	VH3	+0.74	TEC	TEH	22	HOT	600UL
		0.58	127	P2	TWD 26	VH3	-0.97	TEC	TEH	22	HOT	600UL
81	33	0.40	146	P2	TWD 20	VSM	-0.84	TEC	TEH	2	HOT	600UL
		0.72	136	P2	TWD 28	VH3	+0.81	TEC	TEH	2	HOT	600UL
		0.34	62	P2	TWD 17	VH3	+0.28	TEC	TEH	2	HOT	600UL
81	35	0.18	42	P3	TWD 10	DBC	-1.72	TEC	TEH	2	HOT	600UL
81	39	0.35	137	P2	TWD 18	VH3	-0.70	TEC	TEH	2	HOT	600UL
		0.31	103	P2	TWD 16	VC3	+0.83	TEC	TEH	2	HOT	600UL
81	41	0.22	152	P2	TWD 13	VSM	+0.81	TEC	TEH	6	HOT	600UL
		0.33	129	P2	TWD 18	VH3	+0.87	TEC	TEH	6	HOT	600UL
		0.47	65	P2	TWD 23	VH3	+0.00	TEC	TEH	6	HOT	600UL
		0.25	157	P2	TWD 14	VH3	-0.98	TEC	TEH	6	HOT	600UL
81	57	0.33	80	P2	TWD 17	07H	+0.95	TEH	TEC	32	COLD	600UL
81	59	0.26	43	P3	TWD 13	DBH	+1.67	TEH	TEC	31	COLD	600UL
		0.63	130	P2	TWD 26	VC3	-0.72	TEH	TEC	31	COLD	600UL
		0.63	53	P2	TWD 26	VC3	+0.08	TEH	TEC	31	COLD	600UL
81	63	0.43	133	P2	TWD 18	VSM	-0.81	TEH	TEC	34	COLD	600UL
81	65	0.34	144	P2	TWD 17	VH3	-0.81	TEH	TEC	27	COLD	600UL
		0.54	147	P2	TWD 23	VSM	+0.82	TEH	TEC	27	COLD	600UL
81	69	0.21	139	P2	TWD 13	VC3	-0.95	TEH	TEC	33	COLD	600UL
		0.25	93	P2	TWD 15	VSM	-0.78	TEH	TEC	33	COLD	600UL
		0.10	71	P3	TWD 6	DBH	+1.10	TEH	TEC	33	COLD	600UL
		0.16	130	P3	TWD 9	DBH	+1.33	TEH	TEC	33	COLD	600UL
		0.38	31	P2	TWD 20	VH3	+0.02	TEH	TEC	33	COLD	600UL
		0.39	104	P2	TWD 20	VC3	+0.99	TEH	TEC	33	COLD	600UL
81	81	0.36	144	P2	TWD 19	VH3	-0.74	TEH	TEC	1	COLD	600UL
		0.62	113	P2	TWD 27	VC3	-0.63	TEH	TEC	1	COLD	600UL
		0.52	62	P2	TWD 24	VC3	+0.80	TEH	TEC	1	COLD	600UL
		0.37	154	P2	TWD 18	VH3	+0.78	TEH	TEC	1	COLD	600UL
		0.30	136	P2	TWD 15	VSM	+0.82	TEH	TEC	1	COLD	600UL
		0.25	59	P2	TWD 12	VC3	-0.08	TEH	TEC	1	COLD	600UL
81	109	0.25	100	P2	TWD 13	VSM	-0.06	TEH	TEC	7	COLD	600UL
81	121	0.61	108	P2	TWD 26	VH3	-0.89	TEH	TEC	5	COLD	600UL
		0.41	156	P2	TWD 20	VH3	+0.79	TEH	TEC	5	COLD	600UL
81	141	0.38	141	P2	TWD 18	VH3	+0.85	TEC	TEH	3	HOT	600UL
		0.38	149	P2	TWD 18	VH3	-0.83	TEC	TEH	3	HOT	600UL
81	153	0.27	157	P3	TWD 11	DBC	+1.89	TEC	TEH	8	HOT	600UL
82	20	0.15	110	P3	TWD 8	DBC	+2.00	TEC	TEH	2	HOT	600UL
82	22	0.42	107	P3	TWD 17	DBC	+1.67	TEC	TEH	1	HOT	600UL
82	28	0.37	27	P3	TWD 18	DBH	-1.66	TEC	TEH	2	HOT	600UL
82	62	0.33	34	P2	TWD 18	VH3	+0.81	TEH	TEC	32	COLD	600UL

(de01) Post-U3C15 Inspection Results  
 MAI, MCI, MMI, MVI, SAI, SCI, SVI, TWD

QUERY: de01\_inspection\_results.qry

ROW	COL	VOLTS	DEG	CHN	IND	%TW	LOCATION	EXT	EXT	CAL #	LEG	PROBE
		0.22	63	P2	TWD 13	VH3	-0.87	TEH	TEC	32	COLD	600UL
82	68	0.42	145	P2	TWD 17	VH3	-0.82	TEH	TEC	34	COLD	600UL
		0.37	64	P2	TWD 16	VSM	-0.27	TEH	TEC	34	COLD	600UL
		0.33	47	P2	TWD 14	08C	-0.15	TEH	TEC	34	COLD	600UL
82	74	0.41	23	P3	TWD 20	DBH	+1.63	TEH	TEC	36	COLD	600UL
82	84	0.48	87	P3	TWD 21	DBH	-1.61	TEH	TEC	1	COLD	600UL
82	100	0.46	120	P2	TWD 22	VH3	-0.78	TEH	TEC	10	COLD	600UL
		0.35	51	P2	TWD 18	VH3	+0.93	TEH	TEC	10	COLD	600UL
82	110	0.39	65	P2	TWD 18	VH3	+0.70	TEH	TEC	7	COLD	600UL
82	130	0.38	96	P2	TWD 18	VC3	-0.83	TEC	TEH	3	HOT	600UL
		0.63	131	P2	TWD 26	VH3	-0.94	TEC	TEH	3	HOT	600UL
82	132	0.31	119	P2	TWD 15	VH3	-0.84	TEC	TEH	3	HOT	600UL
		0.36	114	P2	TWD 17	VH3	+0.94	TEC	TEH	3	HOT	600UL
82	152	0.36	126	P2	TWD 17	08C	-0.17	TEC	TEH	8	HOT	600UL
83	19	0.40	121	P2	TWD 17	VH2	+0.80	TEC	TEH	1	HOT	600UL
		0.29	65	P2	TWD 13	09C	+1.50	TEC	TEH	1	HOT	600UL
83	25	0.23	29	P3	TWD 11	DBC	-0.79	TEC	TEH	1	HOT	600UL
83	101	0.20	100	P2	TWD 11	07H	-0.66	TEH	TEC	9	COLD	600UL
83	117	0.29	131	P2	TWD 16	05C	+0.49	TEH	TEC	5	COLD	600UL
83	139	0.29	148	P2	TWD 20	VH2	+0.90	TEC	TEH	4	HOT	600UL
83	153	0.52	113	P2	TWD 22	VH2	+0.83	TEC	TEH	8	HOT	600UL
83	157	0.41	110	P2	TWD 19	VH2	+0.94	TEC	TEH	8	HOT	600UL
84	58	0.38	106	P2	TWD 19	09H	-1.29	TEH	TEC	31	COLD	600UL
		0.67	84	P2	TWD 27	09H	+1.73	TEH	TEC	31	COLD	600UL
84	60	0.32	140	P2	TWD 16	09H	-1.61	TEH	TEC	31	COLD	600UL
84	68	0.28	132	P2	TWD 16	09H	-1.50	TEH	TEC	33	COLD	600UL
		0.20	62	P2	TWD 12	09H	+0.66	TEH	TEC	33	COLD	600UL
84	74	0.19	156	P2	TWD 10	VH2	-0.72	TEH	TEC	35	COLD	600UL
84	98	0.20	98	P2	TWD 11	09H	-1.40	TEH	TEC	10	COLD	600UL
84	102	0.34	145	P2	TWD 17	07H	-0.80	TEH	TEC	10	COLD	600UL
		0.22	98	P2	TWD 12	09H	+1.51	TEH	TEC	10	COLD	600UL
		0.42	118	P2	TWD 21	09H	-1.40	TEH	TEC	10	COLD	600UL
84	104	0.20	66	P2	TWD 12	09H	-1.17	TEH	TEC	8	COLD	600UL
84	106	0.28	99	P2	TWD 15	09H	-1.42	TEH	TEC	8	COLD	600UL
		0.60	121	P2	TWD 26	09H	+1.59	TEH	TEC	8	COLD	600UL
84	108	0.37	147	P2	TWD 19	09H	-1.63	TEH	TEC	8	COLD	600UL
		0.33	129	P2	TWD 17	09H	+1.69	TEH	TEC	8	COLD	600UL
84	110	0.30	23	P2	TWD 15	08H	-0.02	TEH	TEC	7	COLD	600UL
		0.38	122	P2	TWD 18	09H	-1.49	TEH	TEC	7	COLD	600UL
		0.64	100	P2	TWD 25	09H	+1.45	TEH	TEC	7	COLD	600UL
84	114	0.45	139	P2	TWD 22	09H	-1.62	TEH	TEC	6	COLD	600UL
		0.37	124	P2	TWD 19	09H	+1.45	TEH	TEC	6	COLD	600UL
84	116	0.34	99	P2	TWD 18	09H	-1.46	TEH	TEC	6	COLD	600UL
		0.52	146	P2	TWD 24	09H	+1.59	TEH	TEC	6	COLD	600UL
84	118	0.35	138	P2	TWD 18	09H	-1.24	TEH	TEC	6	COLD	600UL
84	122	0.39	124	P2	TWD 20	09H	-1.42	TEH	TEC	5	COLD	600UL

(de01) Post-U3C15 Inspection Results  
MAI, MCI, MMI, MVI, SAI, SCI, SVI, TWD

QUERY: de01\_inspection\_results.qry

ROW	COL	VOLTS	DEG	CHN	IND	%TW	LOCATION		EXT	EXT	CAL #	LEG	PROBE
85	61	0.50	94	P2	TWD	23	08H +0.59		TEH	TEC	31	COLD	600UL
85	83	0.22	143	P2	TWD	11	06H +0.82		TEH	TEC	11	COLD	600UL
85	157	0.21	42	P3	TWD	16	DBH +1.80		TEC	TEH	9	HOT	600UL
86	60	0.36	141	P2	TWD	19	08H -0.73		TEH	TEC	32	COLD	600UL
		0.28	99	P2	TWD	16	09H -0.78		TEH	TEC	32	COLD	600UL
86	94	0.24	32	P2	TWD	12	01C -0.95		TEH	TEC	13	COLD	600UL
86	98	0.19	62	P2	TWD	10	06H +0.80		TEH	TEC	10	COLD	600UL
86	102	0.27	164	P2	TWD	14	09H +0.59		TEH	TEC	10	COLD	600UL
86	108	0.28	84	P2	TWD	14	09H +0.64		TEH	TEC	7	COLD	600UL
86	112	0.32	42	P2	TWD	17	08H -0.17		TEH	TEC	6	COLD	600UL
87	61	0.53	47	P2	TWD	25	08H +0.74		TEH	TEC	32	COLD	600UL
87	77	0.24	90	P2	TWD	13	VH2 -0.78		TEH	TEC	2	COLD	600UL
87	99	0.20	124	P2	TWD	11	08H -0.34		TEH	TEC	9	COLD	600UL
		0.25	50	P2	TWD	14	07H +1.00		TEH	TEC	9	COLD	600UL
87	101	0.33	115	P2	TWD	17	07H +0.26		TEH	TEC	9	COLD	600UL
87	111	0.21	111	P2	TWD	10	08H -0.49		TEH	TEC	7	COLD	600UL
87	117	0.32	113	P2	TWD	17	09H +0.32		TEH	TEC	5	COLD	600UL
88	64	0.33	125	P2	TWD	14	VSM -0.72		TEH	TEC	34	COLD	600UL
88	66	0.43	152	P2	TWD	18	VH2 -0.91		TEH	TEC	34	COLD	600UL
88	68	0.29	73	P2	TWD	16	08H -0.96		TEH	TEC	33	COLD	600UL
88	72	0.17	88	P2	TWD	9	VH3 +0.61		TEH	TEC	35	COLD	600UL
88	76	0.51	148	P2	TWD	24	VH2 -0.72		TEH	TEC	1	COLD	600UL
89	29	0.46	111	P2	TWD	22	VH2 +0.06		TEC	TEH	2	HOT	600UL
		0.28	141	P2	TWD	15	VH2 +0.86		TEC	TEH	2	HOT	600UL
89	57	0.42	126	P2	TWD	20	09H +0.55		TEH	TEC	31	COLD	600UL
89	59	0.45	117	P2	TWD	21	09H +0.86		TEH	TEC	31	COLD	600UL
89	61	0.43	112	P2	TWD	20	09H +0.84		TEH	TEC	31	COLD	600UL
89	79	0.42	90	P2	TWD	20	09H -0.19		TEH	TEC	2	COLD	600UL
89	101	0.41	149	P2	TWD	19	07H +0.92		TEH	TEC	9	COLD	600UL
89	109	0.26	55	P2	TWD	13	08H -0.36		TEH	TEC	7	COLD	600UL
		0.21	110	P2	TWD	11	09H +0.57		TEH	TEC	7	COLD	600UL
89	113	0.41	100	P2	TWD	21	09H +0.57		TEH	TEC	5	COLD	600UL
89	151	0.26	113	P2	TWD	19	VC3 -0.94		TEC	TEH	9	HOT	600UL
90	60	0.31	48	P2	TWD	17	08H -0.13		TEH	TEC	32	COLD	600UL
90	72	0.31	85	P2	TWD	16	08H -0.43		TEH	TEC	36	COLD	600UL
90	78	0.32	100	P2	TWD	16	09H -0.06		TEH	TEC	1	COLD	600UL
		0.24	133	P2	TWD	11	09H +0.78		TEH	TEC	1	COLD	600UL
90	102	0.42	122	P2	TWD	21	08H +0.89		TEH	TEC	10	COLD	600UL
		0.17	137	P2	TWD	9	09H +0.89		TEH	TEC	10	COLD	600UL
		0.22	22	P2	TWD	12	09H -0.23		TEH	TEC	10	COLD	600UL
90	116	0.45	147	P2	TWD	22	VH2 -0.78		TEH	TEC	5	COLD	600UL
91	69	0.58	127	P2	TWD	22	08H +0.70		TEH	TEC	34	COLD	600UL

(de01) Post-U3C15 Inspection Results  
 MAI, MCI, MMI, MVI, SAI, SCI, SVI, TWD

QUERY: de01\_inspection\_results.qry

ROW	COL	VOLTS	DEG	CHN	IND	%TW	LOCATION	EXT	EXT	CAL #	LEG	PROBE	
		0.52	94	P2	TWD	20	09H	-0.27	TEH	TEC	34	COLD	600UL
91	73	0.66	148	P2	TWD	28	09H	-0.32	TEH	TEC	36	COLD	600UL
		0.38	132	P2	TWD	19	08H	+0.84	TEH	TEC	36	COLD	600UL
91	79	0.21	74	P2	TWD	13	07H	+0.27	TEH	TEC	1	COLD	600UL
		0.34	85	P2	TWD	18	09H	+0.46	TEH	TEC	1	COLD	600UL
91	99	0.28	109	P2	TWD	15	08H	+0.91	TEH	TEC	9	COLD	600UL
		0.28	46	P2	TWD	15	08H	-0.89	TEH	TEC	9	COLD	600UL
91	103	0.32	113	P2	TWD	16	08H	+0.83	TEH	TEC	9	COLD	600UL
		0.10	127	P2	TWD	6	08H	-0.90	TEH	TEC	9	COLD	600UL
91	105	0.32	76	P2	TWD	16	09H	-0.21	TEH	TEC	7	COLD	600UL
91	111	0.42	61	P2	TWD	18	09H	-0.28	TEH	TEC	7	COLD	600UL
91	113	0.19	118	P2	TWD	11	09H	-0.40	TEH	TEC	5	COLD	600UL
		0.51	97	P2	TWD	24	09H	+0.51	TEH	TEC	5	COLD	600UL
91	115	0.30	135	P2	TWD	16	09H	+0.28	TEH	TEC	6	COLD	600UL
92	42	0.42	84	P2	TWD	19	VH2	-1.11	TEC	TEH	6	HOT	600UL
92	66	0.40	136	P2	TWD	16	09H	-0.13	TEH	TEC	34	COLD	600UL
		0.23	89	P2	TWD	11	09H	+0.93	TEH	TEC	34	COLD	600UL
92	68	0.64	140	P2	TWD	27	09H	-0.17	TEH	TEC	33	COLD	600UL
92	72	0.38	129	P2	TWD	19	09H	-0.02	TEH	TEC	35	COLD	600UL
		0.20	43	P2	TWD	11	09H	+0.65	TEH	TEC	35	COLD	600UL
		0.34	112	P2	TWD	17	05H	+0.82	TEH	TEC	35	COLD	600UL
92	74	0.48	107	P2	TWD	22	07H	+0.85	TEH	TEC	35	COLD	600UL
		0.28	36	P2	TWD	15	09H	+0.95	TEH	TEC	35	COLD	600UL
92	76	0.31	135	P2	TWD	16	09H	-0.48	TEH	TEC	2	COLD	600UL
92	96	0.26	144	P2	TWD	13	09H	-0.13	TEH	TEC	10	COLD	600UL
92	98	0.21	75	P2	TWD	11	08H	-0.47	TEH	TEC	10	COLD	600UL
92	102	0.46	84	P2	TWD	22	09H	+0.93	TEH	TEC	10	COLD	600UL
		0.58	144	P2	TWD	26	09H	-1.00	TEH	TEC	10	COLD	600UL
92	104	0.26	153	P2	TWD	14	09H	-0.30	TEH	TEC	8	COLD	600UL
		0.23	32	P2	TWD	13	09H	+0.87	TEH	TEC	8	COLD	600UL
92	112	0.14	124	P2	TWD	9	09H	-1.21	TEH	TEC	6	COLD	600UL
		0.56	104	P2	TWD	25	09H	+0.34	TEH	TEC	6	COLD	600UL
		0.22	100	P2	TWD	13	09H	+0.91	TEH	TEC	6	COLD	600UL
93	61	0.67	98	P2	TWD	27	09H	+0.72	TEH	TEC	31	COLD	600UL
93	63	0.37	65	P2	TWD	16	09H	+1.02	TEH	TEC	34	COLD	600UL
93	69	0.27	128	P2	TWD	15	09H	+0.72	TEH	TEC	33	COLD	600UL
93	73	0.35	154	P2	TWD	18	09H	+0.80	TEH	TEC	35	COLD	600UL
		0.19	50	P2	TWD	11	08H	-0.87	TEH	TEC	35	COLD	600UL
93	75	0.64	83	P2	TWD	27	09H	-0.25	TEH	TEC	35	COLD	600UL
93	77	0.32	66	P2	TWD	17	09H	-0.25	TEH	TEC	2	COLD	600UL
93	79	0.25	110	P2	TWD	14	09H	-0.17	TEH	TEC	2	COLD	600UL
93	97	0.39	119	P2	TWD	19	09H	-0.19	TEH	TEC	9	COLD	600UL
		0.15	136	P2	TWD	9	09H	+0.83	TEH	TEC	9	COLD	600UL
93	105	0.21	122	P2	TWD	11	08H	-0.49	TEH	TEC	7	COLD	600UL
93	111	0.38	128	P2	TWD	16	08H	+0.30	TEH	TEC	7	COLD	600UL
93	113	0.32	64	P2	TWD	17	09H	+0.70	TEH	TEC	6	COLD	600UL

(de01) Post-U3C15 Inspection Results  
 MAI, MCI, MMI, MVI, SAI, SCI, SVI, TWD

QUERY: de01\_inspection\_results.qry

ROW	COL	VOLTS	DEG	CHN	IND	%TW	LOCATION		EXT	EXT	CAL #	LEG	PROBE
93	149	0.16	31	P3	TWD 13	DBC	-1.60		TEC	TEH	9	HOT	600UL
94	28	0.45	102	P2	TWD 21	VSM	-0.79		TEC	TEH	2	HOT	600UL
		0.29	103	P2	TWD 15	VH3	+0.92		TEC	TEH	2	HOT	600UL
		0.34	102	P2	TWD 17	VH2	-0.97		TEC	TEH	2	HOT	600UL
		0.22	106	P2	TWD 13	VH2	+0.82		TEC	TEH	2	HOT	600UL
94	40	0.80	137	P2	TWD 28	VSM	+0.70		TEC	TEH	5	HOT	600UL
		0.87	121	P2	TWD 29	VH2	-0.94		TEC	TEH	5	HOT	600UL
94	62	0.24	115	P2	TWD 14	09H	+0.06		TEH	TEC	32	COLD	600UL
94	64	0.19	138	P2	TWD 11	08H	-0.43		TEH	TEC	33	COLD	600UL
		0.26	119	P2	TWD 15	09H	+0.36		TEH	TEC	33	COLD	600UL
94	66	0.18	130	P2	TWD 11	09H	+0.61		TEH	TEC	33	COLD	600UL
		0.15	146	P2	TWD 10	VH2	-1.10		TEH	TEC	33	COLD	600UL
94	68	0.49	144	P2	TWD 20	VH2	+0.95		TEH	TEC	34	COLD	600UL
94	72	0.18	114	P2	TWD 10	07H	+0.38		TEH	TEC	36	COLD	600UL
94	74	0.26	72	P2	TWD 14	09H	-0.36		TEH	TEC	35	COLD	600UL
94	78	0.32	149	P2	TWD 17	09H	+0.53		TEH	TEC	1	COLD	600UL
		0.33	113	P2	TWD 16	09H	-0.15		TEH	TEC	1	COLD	600UL
94	82	0.42	147	P2	TWD 21	09H	-0.21		TEH	TEC	12	COLD	600UL
94	84	0.38	66	P2	TWD 17	08H	-0.40		TEH	TEC	11	COLD	600UL
94	88	0.61	133	P2	TWD 24	09H	-0.85		TEH	TEC	11	COLD	600UL
94	94	0.17	145	P2	TWD 10	07H	+0.93		TEH	TEC	14	COLD	600UL
94	96	0.13	32	P2	TWD 8	09H	+0.87		TEH	TEC	9	COLD	600UL
		0.24	41	P2	TWD 13	08H	-0.49		TEH	TEC	9	COLD	600UL
94	102	0.30	113	P2	TWD 16	09H	-0.44		TEH	TEC	10	COLD	600UL
94	104	0.22	103	P3	TWD 14	DBH	+1.16		TEH	TEC	8	COLD	600UL
		0.24	98	P2	TWD 13	09H	+0.40		TEH	TEC	8	COLD	600UL
94	134	0.21	36	P3	TWD 8	DBC	+2.06		TEC	TEH	3	HOT	600UL
94	146	0.64	100	P2	TWD 26	VH3	-0.96		TEC	TEH	3	HOT	600UL
		0.28	69	P2	TWD 14	VH2	+0.81		TEC	TEH	3	HOT	600UL
		0.29	67	P2	TWD 14	VH2	-0.89		TEC	TEH	3	HOT	600UL
94	148	0.29	43	P2	TWD 14	VC3	+0.81		TEC	TEH	3	HOT	600UL
95	63	0.29	96	P2	TWD 16	09H	+0.25		TEH	TEC	33	COLD	600UL
95	65	0.61	67	P2	TWD 25	09H	-0.17		TEH	TEC	27	COLD	600UL
		0.15	159	P2	TWD 8	09H	+0.89		TEH	TEC	27	COLD	600UL
		0.33	71	P2	TWD 16	08H	+0.32		TEH	TEC	27	COLD	600UL
95	67	0.31	142	P2	TWD 17	09H	+0.63		TEH	TEC	33	COLD	600UL
95	69	0.38	128	P2	TWD 16	08H	+0.65		TEH	TEC	34	COLD	600UL
95	71	0.17	155	P2	TWD 11	07H	-0.93		TEH	TEC	33	COLD	600UL
95	73	0.35	158	P2	TWD 18	VSM	+0.82		TEH	TEC	36	COLD	600UL
		0.33	92	P2	TWD 17	VH3	+0.78		TEH	TEC	36	COLD	600UL
		0.49	92	P2	TWD 23	09H	+0.67		TEH	TEC	36	COLD	600UL
		0.31	149	P2	TWD 16	VH3	+0.04		TEH	TEC	36	COLD	600UL
		0.27	26	P2	TWD 14	VC2	+0.04		TEH	TEC	36	COLD	600UL
		0.19	27	P2	TWD 9	07H	-0.88		TEH	TEC	36	COLD	600UL
		0.30	84	P2	TWD 15	07H	+0.64		TEH	TEC	36	COLD	600UL
		0.49	146	P2	TWD 23	VC3	+0.69		TEH	TEC	36	COLD	600UL
95	77	0.24	116	P2	TWD 13	08H	+0.57		TEH	TEC	2	COLD	600UL
95	85	0.29	79	P2	TWD 16	09H	+0.82		TEH	TEC	12	COLD	600UL

(de01) Post-U3C15 Inspection Results  
 MAI, MCI, MMI, MVI, SAI, SCI, SVI, TWD

QUERY: de01\_inspection\_results.qry

ROW	COL	VOLTS	DEG	CHN	IND	%TW	LOCATION	EXT	EXT	CAL #	LEG	PROBE	
		0.29	122	P2	TWD	16	08H	+0.82	TEH	TEC	12	COLD	600UL
95	89	0.26	135	P2	TWD	13	09H	+0.55	TEH	TEC	11	COLD	600UL
95	97	0.26	106	P2	TWD	14	09H	-0.23	TEH	TEC	10	COLD	600UL
95	101	0.53	92	P2	TWD	23	09H	-0.44	TEH	TEC	9	COLD	600UL
		0.17	41	P2	TWD	10	09H	+0.72	TEH	TEC	9	COLD	600UL
95	103	0.36	94	P2	TWD	18	09H	+0.83	TEH	TEC	9	COLD	600UL
95	105	0.56	136	P2	TWD	23	09H	+0.80	TEH	TEC	7	COLD	600UL
		0.22	58	P3	TWD	11	DBH	+0.53	TEH	TEC	7	COLD	600UL
95	109	0.29	87	P2	TWD	14	09H	+0.89	TEH	TEC	7	COLD	600UL
95	111	0.31	86	P2	TWD	17	09H	+1.00	TEH	TEC	6	COLD	600UL
96	60	0.29	47	P2	TWD	16	09H	-0.30	TEH	TEC	32	COLD	600UL
96	66	0.29	42	P2	TWD	12	08H	-0.06	TEH	TEC	34	COLD	600UL
		0.28	47	P2	TWD	13	07H	+0.82	TEH	TEC	34	COLD	600UL
96	68	0.14	27	P2	TWD	9	09H	-0.80	TEH	TEC	33	COLD	600UL
		0.29	100	P2	TWD	16	09H	+0.87	TEH	TEC	33	COLD	600UL
96	70	0.69	132	P2	TWD	29	07H	+0.83	TEH	TEC	33	COLD	600UL
		0.11	154	P2	TWD	7	09H	-0.06	TEH	TEC	33	COLD	600UL
96	72	0.13	85	P2	TWD	7	09H	-0.93	TEH	TEC	35	COLD	600UL
		0.23	44	P2	TWD	12	09H	+0.25	TEH	TEC	35	COLD	600UL
96	80	0.24	158	P2	TWD	14	VH2	-0.82	TEH	TEC	12	COLD	600UL
96	88	0.21	118	P2	TWD	10	07H	+0.22	TEH	TEC	11	COLD	600UL
96	90	0.20	109	P2	TWD	10	09H	+0.57	TEH	TEC	13	COLD	600UL
96	98	0.40	133	P2	TWD	20	09H	+0.64	TEH	TEC	10	COLD	600UL
96	110	0.31	92	P2	TWD	15	09H	+0.13	TEH	TEC	7	COLD	600UL
96	152	0.24	131	P2	TWD	18	02C	+0.84	TEC	TEH	9	HOT	600UL
97	43	0.44	106	P2	TWD	18	VH2	+0.85	TEC	TEH	7	HOT	600UL
97	61	0.16	140	P2	TWD	10	04C	-0.91	TEH	TEC	32	COLD	600UL
97	65	0.32	43	P2	TWD	17	VH2	+0.85	TEH	TEC	33	COLD	600UL
		0.23	154	P2	TWD	13	09H	-0.70	TEH	TEC	33	COLD	600UL
97	69	0.20	40	P2	TWD	12	07H	+0.94	TEH	TEC	33	COLD	600UL
97	73	0.35	117	P2	TWD	17	08H	+0.76	TEH	TEC	35	COLD	600UL
		0.25	145	P2	TWD	13	08H	-0.62	TEH	TEC	35	COLD	600UL
		0.49	118	P2	TWD	23	09H	+0.70	TEH	TEC	35	COLD	600UL
97	85	0.26	136	P2	TWD	12	09H	-0.14	TEH	TEC	11	COLD	600UL
97	103	0.55	131	P2	TWD	24	09H	+0.36	TEH	TEC	9	COLD	600UL
97	107	0.68	99	P2	TWD	26	09H	-0.66	TEH	TEC	7	COLD	600UL
		0.44	53	P2	TWD	20	09H	-0.04	TEH	TEC	7	COLD	600UL
97	141	0.26	133	P2	TWD	18	VH2	+0.88	TEC	TEH	4	HOT	600UL
98	24	0.30	155	P2	TWD	13	06C	+0.87	TEC	TEH	1	HOT	600UL
		0.19	37	P2	TWD	9	06C	+0.00	TEC	TEH	1	HOT	600UL
98	28	0.14	26	P3	TWD	8	DBH	-1.65	TEC	TEH	2	HOT	600UL
98	42	0.38	98	P2	TWD	18	VH2	-0.85	TEC	TEH	6	HOT	600UL
98	64	0.31	140	P2	TWD	17	VH2	-0.83	TEH	TEC	33	COLD	600UL
98	66	0.32	100	P2	TWD	17	09H	+0.87	TEH	TEC	33	COLD	600UL

(de01) Post-U3C15 Inspection Results  
 MAI, MCI, MMI, MVI, SAI, SCI, SVI, TWD

QUERY: de01\_inspection\_results.qry

ROW	COL	VOLTS	DEG	CHN	IND	%TW	LOCATION	EXT	EXT	CAL #	LEG	PROBE
98	68	0.29	49	P3	TWD 24	DBH	+2.22	TEH	TEC	34	COLD	600UL
98	72	0.46	85	P2	TWD 22	07H	+0.83	TEH	TEC	36	COLD	600UL
98	106	0.34	150	P2	TWD 17	09H	+0.87	TEH	TEC	8	COLD	600UL
		0.28	73	P2	TWD 15	09H	-0.18	TEH	TEC	8	COLD	600UL
98	142	0.36	143	P2	TWD 17	VH2	-0.94	TEC	TEH	3	HOT	600UL
99	29	0.31	123	P3	TWD 13	DBH	+1.41	TEC	TEH	1	HOT	600UL
99	65	0.36	122	P2	TWD 16	08H	+0.63	TEH	TEC	34	COLD	600UL
99	79	0.33	111	P2	TWD 18	07H	+0.88	TEH	TEC	1	COLD	600UL
99	81	0.48	145	P2	TWD 23	09H	+0.66	TEH	TEC	12	COLD	600UL
99	89	0.54	127	P2	TWD 22	09H	+0.70	TEH	TEC	11	COLD	600UL
99	93	0.32	91	P2	TWD 17	09H	+0.53	TEH	TEC	14	COLD	600UL
99	99	0.44	130	P2	TWD 21	09H	-0.21	TEH	TEC	9	COLD	600UL
99	101	0.30	124	P2	TWD 15	08H	-0.17	TEH	TEC	9	COLD	600UL
		0.33	108	P2	TWD 17	09H	+0.72	TEH	TEC	9	COLD	600UL
		0.15	25	P3	TWD 8	DBH	+0.51	TEH	TEC	9	COLD	600UL
99	103	0.27	73	P2	TWD 14	09H	+0.64	TEH	TEC	9	COLD	600UL
		0.49	105	P2	TWD 22	09H	+0.89	TEH	TEC	9	COLD	600UL
99	109	0.17	161	P2	TWD 9	09H	+0.72	TEH	TEC	7	COLD	600UL
100	28	0.22	106	P2	TWD 10	08C	+1.03	TEC	TEH	1	HOT	600UL
100	74	0.28	63	P2	TWD 15	09H	-0.15	TEH	TEC	35	COLD	600UL
		0.27	154	P2	TWD 14	09H	+0.91	TEH	TEC	35	COLD	600UL
100	76	0.24	30	P1	SCI	TSH	-0.07	TSH	TSH	136	HOT	580PP
100	100	0.43	137	P2	TWD 21	09H	+0.91	TEH	TEC	10	COLD	600UL
100	102	0.32	103	P2	TWD 17	09H	-0.23	TEH	TEC	10	COLD	600UL
		0.40	106	P2	TWD 20	VH2	-0.85	TEH	TEC	10	COLD	600UL
100	134	0.13	136	P3	TWD 11	DBC	+2.21	TEC	TEH	4	HOT	600UL
101	67	0.50	57	P2	TWD 20	09H	+0.80	TEH	TEC	34	COLD	600UL
101	71	0.25	103	P3	TWD 21	DBH	-1.50	TEH	TEC	34	COLD	600UL
		0.28	155	P2	TWD 13	09H	+0.78	TEH	TEC	34	COLD	600UL
101	77	0.25	149	P2	TWD 15	09H	-0.69	TEH	TEC	1	COLD	600UL
		0.63	113	P2	TWD 27	09H	+0.63	TEH	TEC	1	COLD	600UL
101	79	0.54	62	P2	TWD 24	09H	+0.97	TEH	TEC	1	COLD	600UL
101	81	0.52	145	P2	TWD 21	09H	-0.70	TEH	TEC	11	COLD	600UL
101	83	0.50	126	P2	TWD 21	09H	-0.51	TEH	TEC	11	COLD	600UL
101	85	0.34	119	P2	TWD 16	09H	-0.49	TEH	TEC	11	COLD	600UL
101	97	0.55	120	P2	TWD 24	09H	-0.97	TEH	TEC	9	COLD	600UL
		0.15	30	P2	TWD 9	09H	-0.04	TEH	TEC	9	COLD	600UL
101	101	0.28	115	P2	TWD 15	09H	-0.15	TEH	TEC	9	COLD	600UL
101	113	0.52	19	P3	TWD 23	DBH	+1.20	TEH	TEC	5	COLD	600UL
102	30	0.46	76	P2	TWD 18	08C	-1.01	TEC	TEH	1	HOT	600UL
		0.22	41	P2	TWD 10	08C	+0.09	TEC	TEH	1	HOT	600UL
102	66	0.42	115	P2	TWD 21	VH2	-0.76	TEH	TEC	33	COLD	600UL
		0.24	134	P2	TWD 14	09H	+0.89	TEH	TEC	33	COLD	600UL



(de01) Post-U3C15 Inspection Results  
 MAI, MCI, MMI, MVI, SAI, SCI, SVI, TWD

QUERY: de01\_inspection\_results.qry

ROW	COL	VOLTS	DEG	CHN	IND	%TW	LOCATION		EXT	EXT	CAL #	LEG	PROBE
102	74	0.26	140	P2	TWD	13	09H	+0.84	TEH	TEC	36	COLD	600UL
102	78	0.49	128	P2	TWD	23	09H	+0.92	TEH	TEC	2	COLD	600UL
102	82	0.28	103	P3	TWD	11	DBH	+1.84	TEH	TEC	11	COLD	600UL
		0.27	151	P2	TWD	13	09H	+0.50	TEH	TEC	11	COLD	600UL
102	84	0.25	85	P3	TWD	10	DBH	+1.15	TEH	TEC	11	COLD	600UL
102	92	0.25	133	P3	TWD	16	DBH	+1.92	TEH	TEC	14	COLD	600UL
102	106	0.18	69	P2	TWD	10	04C	+0.89	TEH	TEC	8	COLD	600UL
102	128	0.41	128	P2	TWD	20	VH2	+0.00	TEH	TEC	4	COLD	600UL
103	33	0.44	148	P2	TWD	18	VH2	+0.94	TEC	TEH	1	HOT	600UL
103	65	0.32	139	P2	TWD	13	VC3	-0.80	TEH	TEC	34	COLD	600UL
103	71	0.36	93	P2	TWD	19	09H	+0.84	TEH	TEC	33	COLD	600UL
103	75	0.38	125	P2	TWD	19	09H	-0.80	TEH	TEC	36	COLD	600UL
		0.20	108	P2	TWD	10	09H	+0.70	TEH	TEC	36	COLD	600UL
		0.32	115	P2	TWD	16	09H	+0.97	TEH	TEC	36	COLD	600UL
		0.55	88	P2	TWD	25	VH2	+0.80	TEH	TEC	36	COLD	600UL
		0.26	134	P2	TWD	13	09H	+0.49	TEH	TEC	36	COLD	600UL
103	79	0.32	124	P2	TWD	18	09H	-0.86	TEH	TEC	1	COLD	600UL
		0.36	121	P2	TWD	19	09H	+0.21	TEH	TEC	1	COLD	600UL
		0.35	112	P2	TWD	19	09H	+0.65	TEH	TEC	1	COLD	600UL
103	81	0.51	93	P2	TWD	24	09H	+0.80	TEH	TEC	12	COLD	600UL
103	85	0.30	94	P2	TWD	16	09H	+0.17	TEH	TEC	12	COLD	600UL
103	87	0.31	96	P2	TWD	17	09H	-0.06	TEH	TEC	12	COLD	600UL
103	97	0.17	43	P2	TWD	9	09H	-0.72	TEH	TEC	10	COLD	600UL
		0.40	126	P2	TWD	20	09H	+0.99	TEH	TEC	10	COLD	600UL
104	78	0.23	79	P2	TWD	13	09H	+0.84	TEH	TEC	2	COLD	600UL
104	88	0.37	118	P2	TWD	17	08H	+0.51	TEH	TEC	11	COLD	600UL
105	49	0.25	62	P2	TWD	13	VH2	-0.82	TEH	TEC	30	COLD	600UL
105	81	0.27	32	P2	TWD	13	09H	-0.61	TEH	TEC	11	COLD	600UL
105	101	0.19	109	P2	TWD	10	VH2	+0.30	TEH	TEC	10	COLD	600UL
105	105	0.27	118	P2	TWD	14	VH2	-0.42	TEH	TEC	7	COLD	600UL
105	113	0.24	133	P2	TWD	14	VH2	-0.87	TEH	TEC	5	COLD	600UL
106	48	0.38	22	P3	TWD	17	DBH	+2.10	TEH	TEC	29	COLD	600UL
106	50	0.37	145	P2	TWD	18	VH2	-0.79	TEH	TEC	29	COLD	600UL
		0.49	97	P2	TWD	23	VH2	+0.88	TEH	TEC	29	COLD	600UL
		0.22	128	P2	TWD	12	VH3	+0.90	TEH	TEC	29	COLD	600UL
106	52	0.17	27	P3	TWD	9	DBC	-1.85	TEH	TEC	29	COLD	600UL
106	64	0.34	134	P2	TWD	18	VC2	-0.72	TEH	TEC	33	COLD	600UL
		0.22	60	P2	TWD	13	VC2	-0.13	TEH	TEC	33	COLD	600UL
		0.20	140	P2	TWD	12	VC2	+0.76	TEH	TEC	33	COLD	600UL
106	72	0.45	147	P2	TWD	22	VC2	-0.84	TEH	TEC	36	COLD	600UL
106	86	0.49	96	P2	TWD	21	VH3	-0.89	TEH	TEC	11	COLD	600UL
106	100	0.40	137	P2	TWD	19	09H	-0.78	TEH	TEC	9	COLD	600UL
106	112	0.19	122	P3	TWD	12	DBC	-1.89	TEH	TEC	6	COLD	600UL
106	120	0.15	90	P3	TWD	9	DBC	+1.66	TEH	TEC	5	COLD	600UL

(de01) Post-U3C15 Inspection Results  
 MAI, MCI, MMI, MVI, SAI, SCI, SVI, TWD

QUERY: de01\_inspection\_results.qry

ROW	COL	VOLTS	DEG	CHN	IND	%TW	LOCATION	EXT	EXT	CAL #	LEG	PROBE	
106	134	0.69	118	P2	TWD	27	VH2	-0.92	TEC	TEH	3	HOT	600UL
107	29	0.43	166	P2	TWD	18	VH2	-0.88	TEC	TEH	1	HOT	600UL
107	31	0.27	51	P2	TWD	12	VH2	-1.00	TEC	TEH	1	HOT	600UL
107	143	0.43	111	P2	TWD	26	VH2	-0.89	TEC	TEH	4	HOT	600UL
108	64	0.21	110	P3	TWD	20	DBH	+1.91	TEH	TEC	34	COLD	600UL
108	66	0.16	51	P3	TWD	16	DBH	+2.23	TEH	TEC	34	COLD	600UL
108	100	0.41	135	P2	TWD	20	VH2	-0.80	TEH	TEC	10	COLD	600UL
108	144	0.39	146	P2	TWD	18	VH2	+0.83	TEC	TEH	3	HOT	600UL
109	31	0.29	45	P3	TWD	12	DBC	-1.80	TEC	TEH	1	HOT	600UL
109	37	0.14	166	P3	TWD	8	DBC	+1.35	TEC	TEH	2	HOT	600UL
109	47	0.21	123	P2	TWD	11	09C	-0.91	TEH	TEC	29	COLD	600UL
110	32	0.34	147	P2	TWD	17	02H	-0.98	TEC	TEH	2	HOT	600UL
110	38	0.15	146	P3	TWD	6	DBH	+1.69	TEC	TEH	1	HOT	600UL
110	40	0.12	153	P3	TWD	5	DBH	+1.58	TEC	TEH	1	HOT	600UL
110	42	0.23	148	P2	TWD	14	VH2	-0.89	TEC	TEH	6	HOT	600UL
		0.11	152	P2	TWD	7	VH2	+0.94	TEC	TEH	6	HOT	600UL
110	98	0.51	93	P2	TWD	24	VH2	-0.85	TEH	TEC	10	COLD	600UL
110	140	0.51	150	P2	TWD	22	VH2	+0.75	TEC	TEH	3	HOT	600UL
110	142	0.31	83	P2	TWD	15	VC2	-1.00	TEC	TEH	3	HOT	600UL
111	33	0.39	142	P2	TWD	16	VH2	-0.83	TEC	TEH	1	HOT	600UL
111	35	0.76	89	P2	TWD	26	VH2	-0.99	TEC	TEH	1	HOT	600UL
111	37	0.46	121	P2	TWD	18	VH2	-0.94	TEC	TEH	1	HOT	600UL
111	39	0.42	86	P2	TWD	17	VH2	-0.96	TEC	TEH	1	HOT	600UL
111	43	0.49	93	P2	TWD	23	VH2	-1.04	TEC	TEH	6	HOT	600UL
111	107	0.57	123	P2	TWD	23	VH2	-0.63	TEH	TEC	7	COLD	600UL
112	52	0.43	25	P3	TWD	21	DBH	+1.98	TEH	TEC	30	COLD	600UL
112	64	0.30	96	P2	TWD	14	VH2	-0.89	TEH	TEC	34	COLD	600UL
		0.24	12	P3	TWD	21	DBH	+1.73	TEH	TEC	34	COLD	600UL
112	86	0.17	62	P2	TWD	10	08H	+1.00	TEH	TEC	12	COLD	600UL
112	122	0.49	72	P2	TWD	23	04C	-0.90	TEH	TEC	4	COLD	600UL
112	132	0.28	72	P2	TWD	20	VC2	-0.92	TEC	TEH	4	HOT	600UL
		0.31	42	P2	TWD	21	VC3	+0.64	TEC	TEH	4	HOT	600UL
113	37	0.39	146	P2	TWD	19	VH2	-1.00	TEC	TEH	2	HOT	600UL
113	39	0.44	103	P2	TWD	21	VH2	-0.98	TEC	TEH	2	HOT	600UL
113	41	0.22	171	P3	TWD	11	DBH	+2.09	TEC	TEH	6	HOT	600UL
113	81	0.24	117	P3	TWD	10	DBH	+1.68	TEH	TEC	11	COLD	600UL
113	111	0.52	40	P2	TWD	21	09H	-1.21	TEH	TEC	7	COLD	600UL
113	117	0.17	48	P3	TWD	10	DBH	+1.79	TEH	TEC	5	COLD	600UL
114	34	0.52	61	P3	TWD	20	DBC	+1.86	TEC	TEH	1	HOT	600UL
114	42	0.12	146	P3	TWD	7	DBH	+1.84	TEC	TEH	6	HOT	600UL

(de01) Post-U3C15 Inspection Results  
 MAI, MCI, MMI, MVI, SAI, SCI, SVI, TWD

QUERY: de01\_inspection\_results.qry

ROW	COL	VOLTS	DEG	CHN	IND	%TW	LOCATION	EXT	EXT	CAL #	LEG	PROBE	
114	84	0.19	134	P3	TWD	8	DBH	+1.84	TEH	TEC	11	COLD	600UL
114	92	0.39	96	P3	TWD	22	DBH	+1.88	TEH	TEC	14	COLD	600UL
114	94	0.23	17	P3	TWD	15	DBH	-0.49	TEH	TEC	14	COLD	600UL
114	96	0.31	153	P3	TWD	17	DBH	+1.76	TEH	TEC	9	COLD	600UL
		0.48	104	P2	TWD	20	VH2	-0.82	TEH	TEC	9	COLD	600UL
114	110	0.32	118	P2	TWD	16	VH2	-0.72	TEH	TEC	8	COLD	600UL
114	112	0.40	94	P2	TWD	20	VH2	-0.80	TEH	TEC	5	COLD	600UL
114	126	0.33	113	P2	TWD	17	VC2	-0.89	TEH	TEC	4	COLD	600UL
114	128	0.41	112	P2	TWD	20	VH2	-0.91	TEH	TEC	4	COLD	600UL
114	138	0.47	104	P2	TWD	21	VH2	-0.90	TEC	TEH	3	HOT	600UL
115	39	0.30	93	P2	TWD	13	VH2	-0.99	TEC	TEH	1	HOT	600UL
115	107	0.23	8	P3	TWD	11	DBH	+2.22	TEH	TEC	7	COLD	600UL
115	133	0.35	67	P2	TWD	23	VH1	+0.96	TEC	TEH	4	HOT	600UL
116	54	0.32	33	P3	TWD	15	DBH	+2.11	TEH	TEC	31	COLD	600UL
116	64	0.15	78	P3	TWD	15	DBH	+2.20	TEH	TEC	34	COLD	600UL
116	90	0.18	143	P3	TWD	10	DBH	+1.50	TEH	TEC	13	COLD	600UL
117	43	0.27	155	P2	TWD	13	VH2	-0.98	TEC	TEH	7	HOT	600UL
118	40	0.31	132	P3	TWD	13	DBH	-1.54	TEC	TEH	1	HOT	600UL
118	48	0.42	137	P2	TWD	20	VH1	-0.57	TEH	TEC	30	COLD	600UL
118	58	0.30	11	P3	TWD	24	DBH	+1.77	TEH	TEC	32	COLD	600UL
118	92	0.44	54	P3	TWD	24	DBH	+2.00	TEH	TEC	14	COLD	600UL
119	37	0.16	95	P3	TWD	7	DBC	-1.33	TEC	TEH	1	HOT	600UL
119	45	0.52	111	P2	TWD	23	VH1	+0.85	TEC	TEH	6	HOT	600UL
119	79	0.12	70	P3	TWD	7	DBH	+0.13	TEH	TEC	1	COLD	600UL
119	87	0.19	39	P3	TWD	13	DBH	+0.51	TEH	TEC	12	COLD	600UL
119	91	0.37	72	P3	TWD	17	DBH	+1.99	TEH	TEC	13	COLD	600UL
120	42	0.21	92	P3	TWD	10	DBC	+1.80	TEC	TEH	5	HOT	600UL
120	44	0.42	126	P2	TWD	18	VH1	-1.00	TEC	TEH	7	HOT	600UL
120	56	0.45	116	P2	TWD	21	10H	+1.67	TEH	TEC	31	COLD	600UL
120	66	0.48	65	P2	TWD	20	VH1	-0.78	TEH	TEC	34	COLD	600UL
120	114	0.26	95	P3	TWD	16	DBH	+0.59	TEH	TEC	6	COLD	600UL
120	120	0.46	113	P2	TWD	22	10H	-1.73	TEH	TEC	6	COLD	600UL
120	124	0.39	79	P2	TWD	19	10H	+1.45	TEH	TEC	4	COLD	600UL
121	59	0.19	12	P3	TWD	10	DBC	-1.62	TEH	TEC	31	COLD	600UL
121	65	0.37	51	P2	TWD	19	VH1	+0.82	TEH	TEC	33	COLD	600UL
121	81	0.46	64	P2	TWD	22	VH1	+0.63	TEH	TEC	3	COLD	600UL
121	89	0.17	64	P3	TWD	12	DBH	-1.13	TEH	TEC	14	COLD	600UL
		0.13	149	P3	TWD	9	DBH	+0.36	TEH	TEC	14	COLD	600UL
121	91	0.20	89	P3	TWD	13	DBH	+1.96	TEH	TEC	14	COLD	600UL

(de01) Post-U3C15 Inspection Results  
 MAI, MCI, MMI, MVI, SAI, SCI, SVI, TWD

QUERY: de01\_inspection\_results.qry

ROW	COL	VOLTS	DEG	CHN	IND	%TW	LOCATION		EXT	EXT	CAL #	LEG	PROBE
121	117	0.33	132	P2	TWD	18	VH2	-0.73	TEH	TEC	5	COLD	600UL
121	121	0.09	15	P2	TWD	6	10H	+1.16	TEH	TEC	5	COLD	600UL
122	46	0.49	83	P2	TWD	20	VC2	+0.89	TEC	TEH	7	HOT	600UL
122	48	0.22	63	P2	TWD	12	VH1	+0.57	TEH	TEC	30	COLD	600UL
122	52	0.34	74	P2	TWD	17	VH1	+0.98	TEH	TEC	29	COLD	600UL
122	86	0.25	115	P3	TWD	10	DBH	+1.75	TEH	TEC	11	COLD	600UL
122	110	0.30	154	P2	TWD	16	VH1	-0.88	TEH	TEC	8	COLD	600UL
122	114	0.23	97	P2	TWD	13	VH1	+0.68	TEH	TEC	6	COLD	600UL
122	128	0.35	98	P2	TWD	18	VH2	-0.89	TEH	TEC	4	COLD	600UL
123	43	0.28	132	P2	TWD	13	08C	+0.89	TEC	TEH	7	HOT	600UL
123	49	0.23	50	P2	TWD	12	VH1	-0.99	TEH	TEC	30	COLD	600UL
123	57	0.29	170	P3	TWD	24	DBH	+1.86	TEH	TEC	32	COLD	600UL
123	91	0.15	102	P3	TWD	7	DBH	+1.52	TEH	TEC	13	COLD	600UL
123	95	0.64	137	P2	TWD	27	VH1	+0.89	TEH	TEC	14	COLD	600UL
123	97	0.39	125	P3	TWD	21	DBH	+1.48	TEH	TEC	10	COLD	600UL
124	42	0.26	121	P2	TWD	11	04C	+0.84	TEC	TEH	5	HOT	600UL
124	54	0.18	114	P2	TWD	10	VH1	-0.99	TEH	TEC	29	COLD	600UL
		0.22	113	P2	TWD	12	10H	+0.70	TEH	TEC	29	COLD	600UL
124	56	0.13	147	P3	TWD	8	DBH	+1.95	TEH	TEC	31	COLD	600UL
124	76	0.26	124	P3	TWD	16	DBH	+1.91	TEH	TEC	2	COLD	600UL
124	86	0.14	143	P3	TWD	10	DBH	-0.06	TEH	TEC	12	COLD	600UL
		0.14	81	P3	TWD	9	DBH	+1.79	TEH	TEC	12	COLD	600UL
124	96	0.43	50	P3	TWD	23	DBH	+1.69	TEH	TEC	10	COLD	600UL
		0.11	30	P3	TWD	6	DBH	+0.88	TEH	TEC	10	COLD	600UL
124	110	0.54	106	P2	TWD	25	VH1	-0.17	TEH	TEC	6	COLD	600UL
124	112	0.55	73	P2	TWD	25	VH1	+0.63	TEH	TEC	6	COLD	600UL
124	116	0.62	150	P2	TWD	27	VH1	-0.78	TEH	TEC	6	COLD	600UL
124	120	0.52	120	P2	TWD	24	VH2	-0.88	TEH	TEC	5	COLD	600UL
124	134	0.07	146	P3	TWD	5	DBH	+1.65	TEC	TEH	4	HOT	600UL
125	49	0.30	97	P2	TWD	16	08C	+0.81	TEH	TEC	29	COLD	600UL
125	55	0.42	11	P3	TWD	19	DBH	+1.94	TEH	TEC	31	COLD	600UL
125	67	0.34	52	P2	TWD	18	VH1	+0.97	TEH	TEC	33	COLD	600UL
125	93	0.49	93	P3	TWD	21	DBH	+1.63	TEH	TEC	13	COLD	600UL
125	97	0.24	50	P3	TWD	12	DBH	+1.64	TEH	TEC	9	COLD	600UL
125	99	0.24	54	P3	TWD	12	DBH	+0.59	TEH	TEC	9	COLD	600UL
		0.27	109	P3	TWD	13	DBH	+1.57	TEH	TEC	9	COLD	600UL
125	115	0.28	154	P2	TWD	16	VH1	+0.74	TEH	TEC	5	COLD	600UL
126	52	0.41	140	P2	TWD	20	VH1	+0.83	TEH	TEC	29	COLD	600UL
126	56	0.18	69	P2	TWD	11	VH1	-0.91	TEH	TEC	31	COLD	600UL
126	60	0.56	121	P2	TWD	25	VH1	-0.91	TEH	TEC	32	COLD	600UL

(de01) Post-U3C15 Inspection Results  
 MAI, MCI, MMI, MVI, SAI, SCI, SVI, TWD

QUERY: de01\_inspection\_results.qry

ROW	COL	VOLTS	DEG	CHN	IND	%TW	LOCATION	EXT	EXT	CAL #	LEG	PROBE	
126	62	0.31	127	P2	TWD	17	VH1	-1.10	TEH	TEC	32	COLD	600UL
		0.20	70	P2	TWD	11	VH1	+0.02	TEH	TEC	32	COLD	600UL
126	66	0.41	93	P2	TWD	21	VH1	-0.63	TEH	TEC	33	COLD	600UL
		0.25	62	P2	TWD	15	VH1	+0.95	TEH	TEC	33	COLD	600UL
126	80	0.38	134	P2	TWD	19	VH1	-0.90	TEH	TEC	4	COLD	600UL
126	96	0.39	138	P2	TWD	20	VH1	-0.74	TEH	TEC	10	COLD	600UL
126	100	0.33	99	P2	TWD	17	VH1	-0.88	TEH	TEC	10	COLD	600UL
126	104	0.36	138	P2	TWD	18	VH1	-0.87	TEH	TEC	8	COLD	600UL
126	106	0.45	125	P2	TWD	22	VH1	-0.68	TEH	TEC	8	COLD	600UL
126	108	0.44	146	P2	TWD	21	VH1	-1.12	TEH	TEC	8	COLD	600UL
		0.24	119	P2	TWD	13	VH1	+0.21	TEH	TEC	8	COLD	600UL
126	114	0.28	113	P2	TWD	16	VH1	+0.00	TEH	TEC	6	COLD	600UL
126	118	0.26	161	P2	TWD	15	VH1	+0.85	TEH	TEC	5	COLD	600UL
126	124	0.33	129	P2	TWD	17	VH1	-0.74	TEH	TEC	4	COLD	600UL
127	85	0.28	115	P2	TWD	16	VH2	+0.88	TEH	TEC	12	COLD	600UL
127	103	0.33	115	P2	TWD	17	VH1	-0.70	TEH	TEC	9	COLD	600UL
		0.68	97	P2	TWD	27	VH1	+0.89	TEH	TEC	9	COLD	600UL
127	107	0.24	46	P2	TWD	12	VH1	-0.08	TEH	TEC	7	COLD	600UL
127	111	0.29	150	P2	TWD	16	VH1	-0.88	TEH	TEC	5	COLD	600UL
127	115	0.38	95	P2	TWD	19	VH1	+0.87	TEH	TEC	5	COLD	600UL
127	119	0.20	138	P2	TWD	12	VH1	-0.96	TEH	TEC	5	COLD	600UL
128	46	0.23	134	P2	TWD	12	O2C	+0.90	TEC	TEH	6	HOT	600UL
128	58	0.37	106	P2	TWD	19	VH3	+0.78	TEH	TEC	32	COLD	600UL
		0.16	26	P2	TWD	10	VH3	+0.30	TEH	TEC	32	COLD	600UL
128	78	0.44	142	P2	TWD	21	VH1	-0.92	TEH	TEC	2	COLD	600UL
128	84	0.32	143	P2	TWD	15	VH1	+0.91	TEH	TEC	11	COLD	600UL
		0.34	153	P2	TWD	16	VH2	-0.91	TEH	TEC	11	COLD	600UL
128	100	0.52	147	P2	TWD	24	VH1	-0.82	TEH	TEC	10	COLD	600UL
		0.34	148	P2	TWD	17	VH2	-0.84	TEH	TEC	10	COLD	600UL
128	106	0.48	144	P2	TWD	23	VH1	-0.82	TEH	TEC	8	COLD	600UL
128	130	0.20	73	P2	TWD	15	O8C	-0.98	TEC	TEH	4	HOT	600UL
129	75	0.38	118	P2	TWD	19	VH1	+0.82	TEH	TEC	35	COLD	600UL
129	99	0.53	72	P2	TWD	23	10H	-0.25	TEH	TEC	9	COLD	600UL
129	129	0.37	131	P3	TWD	18	DBH	+2.01	TEH	TEC	3	COLD	600UL
130	54	0.28	146	P3	TWD	14	DBH	-1.81	TEH	TEC	29	COLD	600UL
130	56	0.14	152	P3	TWD	8	DBH	-1.67	TEH	TEC	31	COLD	600UL
130	68	0.39	143	P2	TWD	20	VH1	-0.78	TEH	TEC	33	COLD	600UL
		0.47	147	P2	TWD	23	VH2	-0.89	TEH	TEC	33	COLD	600UL
130	72	0.24	146	P2	TWD	13	VH1	-0.84	TEH	TEC	35	COLD	600UL
130	74	0.46	127	P2	TWD	22	VH1	-0.87	TEH	TEC	35	COLD	600UL
130	76	0.56	115	P2	TWD	25	VH1	+0.76	TEH	TEC	2	COLD	600UL
130	78	0.32	136	P2	TWD	17	VH1	-0.90	TEH	TEC	2	COLD	600UL

(de01) Post-U3C15 Inspection Results  
MAI, MCI, MMI, MVI, SAI, SCI, SVI, TWD

QUERY: de01\_inspection\_results.qry

ROW	COL	VOLTS	DEG	CHN	IND	%TW	LOCATION	EXT	EXT	CAL #	LEG	PROBE	
130	84	0.58	119	P2	TWD 26		VH1	-0.99	TEH	TEC	12	COLD	600UL
		0.23	113	P2	TWD 13		VH1	+0.74	TEH	TEC	12	COLD	600UL
130	88	0.28	78	P2	TWD 16		VH1	+0.11	TEH	TEC	12	COLD	600UL
		0.15	154	P2	TWD 9		VH1	+0.69	TEH	TEC	12	COLD	600UL
130	106	0.45	141	P2	TWD 22		VH1	-0.80	TEH	TEC	8	COLD	600UL
		0.24	82	P2	TWD 13		VH1	-0.22	TEH	TEC	8	COLD	600UL
130	128	0.42	90	P2	TWD 20		VH2	-0.95	TEH	TEC	4	COLD	600UL
131	51	0.55	131	P2	TWD 25		VH2	+0.82	TEH	TEC	54	COLD	600UL
		0.52	111	P3	TWD 22		DBC	+1.79	TEH	TEC	54	COLD	600UL
131	55	0.23	17	P3	TWD 12		DBH	+1.63	TEH	TEC	54	COLD	600UL
131	57	0.21	124	P3	TWD 11		DBH	+2.05	TEH	TEC	54	COLD	600UL
131	83	0.29	76	P2	TWD 16		VH1	-1.01	TEH	TEC	54	COLD	600UL
		0.34	38	P2	TWD 18		VH1	-0.80	TEH	TEC	54	COLD	600UL
131	89	0.18	93	P2	TWD 10		VH1	-0.94	TEH	TEC	52	COLD	600UL
131	97	0.17	29	P2	TWD 10		VH1	-0.92	TEH	TEC	52	COLD	600UL
		0.29	97	P2	TWD 15		VH1	+0.92	TEH	TEC	52	COLD	600UL
132	54	0.20	119	P3	TWD 10		DBH	-1.51	TEH	TEC	54	COLD	600UL
132	56	0.13	59	P3	TWD 7		DBH	-1.92	TEH	TEC	54	COLD	600UL
132	70	0.18	100	P2	TWD 11		VH1	+0.21	TEH	TEC	54	COLD	600UL
		0.62	109	P2	TWD 27		VH1	+0.71	TEH	TEC	54	COLD	600UL
132	96	0.20	149	P2	TWD 12		VH1	+0.67	TEH	TEC	52	COLD	600UL
		0.41	121	P2	TWD 20		VH1	-0.85	TEH	TEC	52	COLD	600UL
132	100	0.46	137	P2	TWD 22		VH1	-0.92	TEH	TEC	52	COLD	600UL
132	118	0.09	141	P3	TWD 4		DBH	+1.74	TEH	TEC	52	COLD	600UL
133	51	0.19	59	P2	TWD 11		08C	+0.85	TEH	TEC	55	COLD	600UL
133	57	0.30	19	P3	TWD 16		DBH	-1.38	TEH	TEC	55	COLD	600UL
133	61	0.12	152	P3	TWD 7		DBC	-1.49	TEH	TEC	55	COLD	600UL
133	75	0.42	53	P2	TWD 20		10H	+0.79	TEH	TEC	55	COLD	600UL
133	91	0.22	112	P2	TWD 13		VH1	+0.89	TEH	TEC	53	COLD	600UL
		0.13	117	P2	TWD 8		VH1	-0.86	TEH	TEC	53	COLD	600UL
133	101	0.21	155	P2	TWD 12		VH1	-1.00	TEH	TEC	53	COLD	600UL
134	58	0.27	145	P2	TWD 15		VH1	-0.92	TEH	TEC	54	COLD	600UL
		0.33	93	P2	TWD 18		VC1	-0.94	TEH	TEC	54	COLD	600UL
		0.32	149	P2	TWD 17		VC2	-0.77	TEH	TEC	54	COLD	600UL
134	60	0.44	85	P3	TWD 21		DBH	+1.66	TEH	TEC	55	COLD	600UL
134	74	0.33	91	P2	TWD 18		VH1	-0.90	TEH	TEC	54	COLD	600UL
134	88	0.61	134	P2	TWD 26		VH1	-0.87	TEH	TEC	52	COLD	600UL
134	90	0.18	127	P2	TWD 10		VH1	+0.83	TEH	TEC	52	COLD	600UL
134	94	0.33	142	P2	TWD 18		VH1	-0.87	TEH	TEC	53	COLD	600UL
		0.20	105	P2	TWD 12		VH1	+0.91	TEH	TEC	53	COLD	600UL
134	96	0.43	144	P2	TWD 22		VH1	-0.91	TEH	TEC	53	COLD	600UL
134	102	0.32	152	P2	TWD 17		VH2	+0.83	TEH	TEC	52	COLD	600UL
134	110	0.54	151	P2	TWD 25		VH1	-0.89	TEH	TEC	53	COLD	600UL
134	120	0.35	107	P2	TWD 18		VH1	-0.65	TEH	TEC	53	COLD	600UL

(de01) Post-U3C15 Inspection Results  
 MAI, MCI, MMI, MVI, SAI, SCI, SVI, TWD

QUERY: de01\_inspection\_results.qry

ROW	COL	VOLTS	DEG	CHN	IND	%TW	LOCATION		EXT	EXT	CAL #	LEG	PROBE
135	57	0.35	11	P3	TWD 17	DBH	+2.13		TEH	TEC	54	COLD	600UL
135	97	0.43	80	P2	TWD 21	VH1	-0.86		TEH	TEC	52	COLD	600UL
136	62	0.33	109	P2	TWD 17	VH2	-1.24		TEH	TEC	55	COLD	600UL
136	70	0.57	52	P2	TWD 24	VH1	+1.00		TEH	TEC	55	COLD	600UL
136	76	0.49	56	P2	TWD 22	VH1	-0.94		TEH	TEC	55	COLD	600UL
		0.45	114	P2	TWD 21	VH1	+0.60		TEH	TEC	55	COLD	600UL
		0.42	79	P2	TWD 20	VH2	-1.18		TEH	TEC	55	COLD	600UL
136	78	0.54	124	P2	TWD 24	VH1	-0.98		TEH	TEC	55	COLD	600UL
136	82	0.44	143	P2	TWD 21	VH1	-1.12		TEH	TEC	55	COLD	600UL
136	84	0.31	67	P2	TWD 17	VH1	-0.92		TEH	TEC	54	COLD	600UL
		0.31	89	P2	TWD 17	VH1	+0.57		TEH	TEC	54	COLD	600UL
136	100	0.30	133	P2	TWD 16	VH1	-0.96		TEH	TEC	52	COLD	600UL
		0.18	157	P2	TWD 10	VH1	+0.73		TEH	TEC	52	COLD	600UL
136	108	0.43	135	P2	TWD 21	VH1	-0.94		TEH	TEC	52	COLD	600UL
		0.31	108	P2	TWD 16	VH1	+0.73		TEH	TEC	52	COLD	600UL
136	112	0.44	49	P2	TWD 21	VH1	-0.65		TEH	TEC	53	COLD	600UL
136	118	0.21	29	P3	TWD 14	DBH	+1.06		TEH	TEC	53	COLD	600UL
137	59	0.35	9	P3	TWD 18	DBH	+1.92		TEH	TEC	55	COLD	600UL
		0.44	109	P3	TWD 21	DBC	+2.00		TEH	TEC	55	COLD	600UL
137	67	0.47	18	P3	TWD 22	DBH	+2.08		TEH	TEC	55	COLD	600UL
137	69	0.20	147	P2	TWD 11	VH1	+0.85		TEH	TEC	55	COLD	600UL
		0.36	144	P2	TWD 18	VH1	-0.89		TEH	TEC	55	COLD	600UL
137	85	0.23	46	P2	TWD 13	09H	+0.85		TEH	TEC	55	COLD	600UL
		0.07	152	P2	TWD 4	09H	-0.90		TEH	TEC	55	COLD	600UL
137	89	0.15	142	P2	TWD 9	VH1	-0.91		TEH	TEC	53	COLD	600UL
		0.30	130	P2	TWD 15	VH1	+0.83		TEH	TEC	53	COLD	600UL
137	91	0.12	7	P3	TWD 9	DBC	+1.68		TEH	TEC	53	COLD	600UL
137	93	0.28	61	P2	TWD 16	VH1	-0.91		TEH	TEC	53	COLD	600UL
137	103	0.58	65	P2	TWD 25	VH1	-0.89		TEH	TEC	52	COLD	600UL
		0.42	43	P2	TWD 20	VH1	+0.65		TEH	TEC	52	COLD	600UL
138	68	0.20	61	P3	TWD 10	DBH	+2.09		TEH	TEC	54	COLD	600UL
138	70	0.17	28	P3	TWD 9	DBH	+2.23		TEH	TEC	54	COLD	600UL
138	76	0.30	91	P2	TWD 16	VH1	-0.19		TEH	TEC	54	COLD	600UL
		0.17	164	P2	TWD 10	VH1	+0.83		TEH	TEC	54	COLD	600UL
		0.49	134	P2	TWD 23	VH2	-0.79		TEH	TEC	54	COLD	600UL
138	78	0.37	153	P2	TWD 19	VH2	-0.83		TEH	TEC	54	COLD	600UL
138	94	0.35	83	P2	TWD 17	VH1	+0.86		TEH	TEC	52	COLD	600UL
139	93	0.22	133	P2	TWD 13	VC1	+0.89		TEH	TEC	53	COLD	600UL
139	111	0.35	126	P3	TWD 16	DBH	+1.69		TEH	TEC	52	COLD	600UL
140	64	0.39	147	P2	TWD 19	VH2	-0.83		TEH	TEC	55	COLD	600UL
140	66	0.25	30	P3	TWD 14	DBH	-1.62		TEH	TEC	55	COLD	600UL
140	72	0.35	21	P3	TWD 17	DBH	+1.54		TEH	TEC	54	COLD	600UL
140	76	0.67	123	P2	TWD 27	VH1	-0.98		TEH	TEC	55	COLD	600UL
		0.44	149	P2	TWD 21	VH2	-0.85		TEH	TEC	55	COLD	600UL

(de01) Post-U3C15 Inspection Results  
 MAI, MCI, MMI, MVI, SAI, SCI, SVI, TWD

QUERY: de01\_inspection\_results.qry

ROW	COL	VOLTS	DEG	CHN	IND	%TW	LOCATION		EXT	EXT	CAL #	LEG	PROBE
140	106	0.24	71	P3	TWD	16	DBH	+2.14	TEH	TEC	53	COLD	600UL
141	63	0.32	139	P2	TWD	17	08H	+0.75	TEH	TEC	55	COLD	600UL
		0.35	79	P3	TWD	18	DBH	-1.88	TEH	TEC	55	COLD	600UL
		0.37	130	P2	TWD	18	09H	-0.29	TEH	TEC	55	COLD	600UL
		0.37	140	P2	TWD	18	VH1	-0.85	TEH	TEC	55	COLD	600UL
141	67	0.31	66	P3	TWD	16	DBH	+1.72	TEH	TEC	55	COLD	600UL
141	69	0.34	4	P3	TWD	17	DBC	+1.53	TEH	TEC	54	COLD	600UL
		0.22	50	P3	TWD	11	DBH	+1.84	TEH	TEC	54	COLD	600UL
141	71	0.23	92	P3	TWD	13	DBH	+1.73	TEH	TEC	55	COLD	600UL
141	75	0.29	154	P3	TWD	15	DBH	-1.69	TEH	TEC	55	COLD	600UL
		0.22	34	P3	TWD	12	DBH	+1.70	TEH	TEC	55	COLD	600UL
141	81	0.23	58	P3	TWD	13	DBH	-2.22	TEH	TEC	55	COLD	600UL
141	83	0.58	118	P2	TWD	25	VC1	+0.90	TEH	TEC	55	COLD	600UL
141	93	0.22	152	P2	TWD	13	VC1	+0.87	TEH	TEC	53	COLD	600UL
141	97	0.32	119	P2	TWD	17	VH2	+1.00	TEH	TEC	53	COLD	600UL
141	113	0.22	19	P3	TWD	15	DBH	+2.07	TEH	TEC	53	COLD	600UL
		0.24	137	P2	TWD	14	09C	+0.71	TEH	TEC	53	COLD	600UL
142	72	0.32	147	P3	TWD	17	DBH	-1.82	TEH	TEC	55	COLD	600UL
		0.30	58	P3	TWD	16	DBH	+1.91	TEH	TEC	55	COLD	600UL
		0.55	150	P2	TWD	24	VH1	+0.71	TEH	TEC	55	COLD	600UL
142	74	0.29	48	P3	TWD	15	DBH	+2.06	TEH	TEC	55	COLD	600UL
142	82	0.67	108	P2	TWD	28	VH2	-0.90	TEH	TEC	54	COLD	600UL
142	92	0.32	154	P2	TWD	17	VH1	-0.86	TEH	TEC	54	COLD	600UL
142	94	0.18	35	P2	TWD	10	VH1	+0.88	TEH	TEC	54	COLD	600UL
142	98	0.23	148	P2	TWD	13	VH1	+0.58	TEH	TEC	53	COLD	600UL
142	104	0.25	131	P3	TWD	15	DBH	+2.14	TEH	TEC	53	COLD	600UL
142	108	0.24	142	P2	TWD	14	VH3	+0.87	TEH	TEC	53	COLD	600UL
142	110	0.19	83	P3	TWD	13	DBH	+1.93	TEH	TEC	53	COLD	600UL
143	75	0.31	68	P3	TWD	15	DBH	+1.61	TEH	TEC	54	COLD	600UL
143	83	0.16	123	P3	TWD	9	DBC	+2.01	TEH	TEC	54	COLD	600UL
143	89	0.20	103	P2	TWD	12	08C	+0.90	TEH	TEC	54	COLD	600UL
143	91	0.35	31	P2	TWD	18	VC1	-0.87	TEH	TEC	55	COLD	600UL
143	99	0.15	24	P3	TWD	8	DBC	+1.67	TEH	TEC	52	COLD	600UL
143	101	0.30	62	P2	TWD	16	VC1	-0.87	TEH	TEC	52	COLD	600UL
		0.11	37	P3	TWD	6	DBC	+1.73	TEH	TEC	52	COLD	600UL
143	105	0.50	28	P3	TWD	27	DBH	+1.71	TEH	TEC	53	COLD	600UL
		0.40	91	P3	TWD	23	DBC	+1.61	TEH	TEC	53	COLD	600UL
		0.40	67	P3	TWD	22	DBH	-1.81	TEH	TEC	53	COLD	600UL
144	80	0.52	148	P3	TWD	23	DBC	+2.06	TEH	TEC	55	COLD	600UL
144	82	0.61	121	P2	TWD	26	VH2	-0.96	TEH	TEC	55	COLD	600UL
		0.13	73	P3	TWD	8	DBC	+2.02	TEH	TEC	55	COLD	600UL
		0.27	124	P3	TWD	15	DBH	+1.77	TEH	TEC	55	COLD	600UL
144	90	0.17	178	P3	TWD	10	DBC	+2.01	TEH	TEC	55	COLD	600UL
		0.20	101	P2	TWD	12	06C	+0.98	TEH	TEC	55	COLD	600UL
		0.19	82	P2	TWD	11	06C	-0.89	TEH	TEC	55	COLD	600UL
144	92	0.29	34	P2	TWD	16	10C	-0.96	TEH	TEC	54	COLD	600UL



(de01) Post-U3C15 Inspection Results  
 MAI, MCI, MMI, MVI, SAI, SCI, SVI, TWD

QUERY: de01\_inspection\_results.qry

ROW	COL	VOLTS	DEG	CHN	IND	%TW	LOCATION		EXT	EXT	CAL #	LEG	PROBE
144	96	0.33	68	P3	TWD 20	DBH	+1.99		TEH	TEC	53	COLD	600UL
		0.27	33	P2	TWD 15	VH1	+0.23		TEH	TEC	53	COLD	600UL
		0.81	94	P2	TWD 32	VH1	+0.85		TEH	TEC	53	COLD	600UL
144	102	0.28	54	P3	TWD 18	DBH	+2.05		TEH	TEC	53	COLD	600UL
		0.44	56	P2	TWD 22	VC3	+0.83		TEH	TEC	53	COLD	600UL
145	73	0.55	96	P3	TWD 24	DBH	+1.87		TEH	TEC	55	COLD	600UL
145	91	0.09	150	P3	TWD 5	DBH	+1.94		TEH	TEC	54	COLD	600UL
		0.47	84	P2	TWD 23	VC1	-0.96		TEH	TEC	54	COLD	600UL
145	93	0.31	54	P2	TWD 16	VC1	+0.27		TEH	TEC	55	COLD	600UL
		0.53	89	P3	TWD 23	DBC	+1.59		TEH	TEC	55	COLD	600UL
145	95	0.16	36	P3	TWD 8	DBC	-1.45		TEH	TEC	54	COLD	600UL
145	101	0.26	47	P3	TWD 17	DBH	-1.41		TEH	TEC	53	COLD	600UL
146	92	0.47	89	P3	TWD 22	DBC	+1.65		TEH	TEC	55	COLD	600UL
		0.36	72	P2	TWD 18	VC1	+1.02		TEH	TEC	55	COLD	600UL
		0.39	111	P2	TWD 19	10C	+0.79		TEH	TEC	55	COLD	600UL
147	91	0.68	105	P2	TWD 27	VC1	-0.91		TEH	TEC	55	COLD	600UL
		0.64	109	P2	TWD 26	VC1	+0.68		TEH	TEC	55	COLD	600UL
147	93	0.70	136	P2	TWD 28	VH2	-0.68		TEH	TEC	55	COLD	600UL

Total Tubes : 802  
 Total Records: 1126

**Appendix 4**  
**Tube Inspection Summary**  
**Steam Generator E-089**

(de01) Post-U3C15 Inspection Results  
 MAI, MCI, MMI, MVI, SAI, SCI, SVI, TWD

QUERY: de01\_inspection\_results

ROW	COL	VOLTS	DEG	CHN	IND	%TW	LOCATION	EXT	EXT	CAL #	LEG	PROBE	
14	110	0.24	28	P3	TWD	11	DBH	-1.95	TEH	TEC	54	COLD	600UL
21	67	0.61	81	P2	TWD	22	VSM	-0.72	TEH	TEC	33	COLD	600UL
22	66	0.25	42	P2	TWD	11	VSM	-0.82	TEH	TEC	30	COLD	600UL
22	134	0.24	127	P2	TWD	12	VSM	-0.72	TEC	TEH	20	HOT	600UL
24	22	0.24	141	P2	TWD	14	VSM	-0.78	TEC	TEH	18	HOT	600UL
24	68	0.41	49	P3	TWD	15	DBH	+1.77	TEH	TEC	32	COLD	600UL
		0.25	76	P2	TWD	12	VSM	-0.77	TEH	TEC	32	COLD	600UL
25	65	0.44	117	P2	TWD	16	VSM	+1.17	TEH	TEC	31	COLD	600UL
25	67	0.34	100	P2	TWD	14	VSM	-1.18	TEH	TEC	33	COLD	600UL
25	115	0.70	106	P2	TWD	26	VSM	+0.82	TEH	TEC	53	COLD	600UL
26	48	0.75	32	P2	TWD	26	VSM	-1.04	TEH	TEC	28	COLD	600UL
27	39	0.27	29	P1	SCI		TSH	-0.13	TSH	TSH	56	HOT	580PP
29	107	0.36	92	P3	TWD	15	DBC	-1.80	TEH	TEC	55	COLD	600UL
30	122	0.28	62	P2	TWD	12	05H	+0.49	TEH	TEC	51	COLD	600UL
31	51	0.34	125	P2	TWD	13	06H	+0.78	TEH	TEC	31	COLD	600UL
31	125	0.42	24	P1	SCI		TSH	+0.02	TSH	TSH	49	HOT	580PP
31	167	0.26	16	P2	TWD	13	VSM	+0.99	TEC	TEH	37	HOT	600UL
32	118	0.40	106	P2	TWD	17	VSM	-0.86	TEH	TEC	53	COLD	600UL
33	61	0.74	46	P2	TWD	23	VSM	-0.04	TEH	TEC	31	COLD	600UL
		0.60	135	P2	TWD	20	VSM	+0.89	TEH	TEC	31	COLD	600UL
33	171	0.24	127	P2	TWD	10	01C	-0.12	TEC	TEH	36	HOT	600UL
34	148	0.43	103	P2	TWD	19	VSM	-0.81	TEC	TEH	29	HOT	600UL
35	113	0.46	84	P2	TWD	19	VSM	-0.92	TEH	TEC	53	COLD	600UL
		0.29	22	P2	TWD	13	VSM	-0.11	TEH	TEC	53	COLD	600UL
36	30	0.36	99	P2	TWD	18	VSM	+0.80	TEC	TEH	18	HOT	600UL
36	34	0.14	60	P2	TWD	8	VSM	+0.80	TEC	TEH	14	HOT	600UL
36	36	0.38	83	P2	TWD	16	01H	+0.78	TEC	TEH	15	HOT	600UL
36	50	0.16	154	P3	TWD	9	DBH	+2.00	TEH	TEC	33	COLD	600UL
36	68	0.51	12	2	MAI		TSH	-1.58	TSH	TSH	104	HOT	580PP
36	72	0.51	133	P3	TWD	18	DBH	-1.79	TEH	TEC	32	COLD	600UL
36	104	0.26	162	P3	TWD	11	DBH	+1.57	TEH	TEC	55	COLD	600UL
		0.21	5	P3	TWD	9	DBC	+1.21	TEH	TEC	55	COLD	600UL
36	144	0.34	111	P2	TWD	16	VSM	-0.82	TEC	TEH	24	HOT	600UL
36	146	0.34	68	P2	TWD	16	VSM	+0.78	TEC	TEH	24	HOT	600UL
37	53	0.42	104	P2	TWD	17	VSM	+0.04	TEH	TEC	33	COLD	600UL
37	145	0.48	100	P2	TWD	21	VSM	+0.82	TEC	TEH	24	HOT	600UL
37	157	0.25	42	P2	TWD	12	VSM	+0.80	TEC	TEH	32	HOT	600UL
37	171	0.61	121	P2	TWD	23	VSM	-0.84	TEC	TEH	36	HOT	600UL
38	28	0.34	103	P2	TWD	14	VSM	-0.83	TEC	TEH	19	HOT	600UL
		0.41	44	P2	TWD	17	VSM	+0.81	TEC	TEH	19	HOT	600UL

(de01) Post-U3C15 Inspection Results  
 MAI, MCI, MMI, MVI, SAI, SCI, SVI, TWD

QUERY: de01\_inspection\_results.qry

ROW	COL	VOLTS	DEG	CHN	IND	TW	LOCATION		EXT	EXT	CAL #	LEG	PROBE
38	38	0.35	27	P2	TWD	15	VSM	-0.02	TEC	TEH	15	HOT	600UL
38	56	0.23	131	P2	TWD	11	06H	+0.50	TEH	TEC	34	COLD	600UL
38	128	0.22	136	P2	TWD	9	VSM	+0.86	TEH	TEC	50	COLD	600UL
38	162	0.27	95	P2	TWD	13	VSM	-0.06	TEC	TEH	33	HOT	600UL
		0.31	124	P2	TWD	15	VSM	-0.82	TEC	TEH	33	HOT	600UL
39	41	0.28	75	P3	TWD	14	DBH	-1.62	TEC	TEH	10	HOT	600UL
39	43	0.47	115	P2	TWD	19	VSM	+0.91	TEC	TEH	11	HOT	600UL
39	69	0.45	151	P2	TWD	17	VSM	+0.65	TEH	TEC	35	COLD	600UL
39	101	0.37	32	P3	TWD	13	DBH	-1.49	TEH	TEC	20	COLD	600UL
39	117	0.32	126	P2	TWD	13	VSM	-0.81	TEH	TEC	54	COLD	600UL
		0.28	137	P2	TWD	11	VSM	+0.80	TEH	TEC	54	COLD	600UL
39	147	0.41	129	P2	TWD	18	VSM	+0.81	TEC	TEH	28	HOT	600UL
40	66	0.17	22	P3	TWD	9	DBC	+1.68	TEH	TEC	35	COLD	600UL
40	68	0.46	20	P2	TWD	19	VSM	-0.78	TEH	TEC	34	COLD	600UL
40	146	0.43	53	P2	TWD	19	VSM	+0.78	TEC	TEH	24	HOT	600UL
40	162	0.39	118	P2	TWD	17	VSM	-0.73	TEC	TEH	32	HOT	600UL
		0.22	36	P2	TWD	11	VSM	-0.04	TEC	TEH	32	HOT	600UL
40	168	0.67	45	P2	TWD	24	VSM	+0.90	TEC	TEH	36	HOT	600UL
		0.40	49	P2	TWD	16	VSM	-0.08	TEC	TEH	36	HOT	600UL
		0.20	157	P2	TWD	8	VSM	-0.69	TEC	TEH	36	HOT	600UL
40	170	0.42	140	P2	TWD	18	01C	+0.89	TEC	TEH	37	HOT	600UL
41	7	0.46	81	P2	TWD	21	VSM	+0.88	TEC	TEH	30	HOT	600UL
		0.41	114	P2	TWD	19	VSM	-0.78	TEC	TEH	30	HOT	600UL
41	39	0.22	167	P3	TWD	12	DBC	+1.52	TEC	TEH	10	HOT	600UL
41	47	0.44	127	P2	TWD	18	VSM	+0.00	TEH	TEC	33	COLD	600UL
		0.44	129	P2	TWD	18	VSM	+0.82	TEH	TEC	33	COLD	600UL
41	55	0.29	86	P2	TWD	13	VSM	-0.84	TEH	TEC	34	COLD	600UL
41	59	0.55	91	P2	TWD	21	VSM	-0.73	TEH	TEC	34	COLD	600UL
		0.54	124	P2	TWD	21	VSM	+0.00	TEH	TEC	34	COLD	600UL
41	63	0.63	92	P2	TWD	24	VSM	-0.71	TEH	TEC	34	COLD	600UL
		0.76	72	P2	TWD	26	VSM	+0.04	TEH	TEC	34	COLD	600UL
41	69	0.55	87	P2	TWD	21	VSM	+0.80	TEH	TEC	34	COLD	600UL
41	103	0.66	104	P3	TWD	24	DBC	+1.75	TEH	TEC	55	COLD	600UL
41	107	0.28	23	P2	TWD	14	VSM	-0.54	TEH	TEC	55	COLD	600UL
		0.28	66	P2	TWD	14	VSM	+1.08	TEH	TEC	55	COLD	600UL
41	113	0.50	124	P2	TWD	18	VSM	-0.85	TEH	TEC	54	COLD	600UL
		0.21	127	P2	TWD	8	VSM	-0.12	TEH	TEC	54	COLD	600UL
41	123	0.58	111	P2	TWD	20	VSM	+0.86	TEH	TEC	52	COLD	600UL
		0.25	150	P2	TWD	10	VSM	-0.59	TEH	TEC	52	COLD	600UL
41	131	0.57	64	P2	TWD	23	VSM	+0.70	TEC	TEH	21	HOT	600UL
		0.56	101	P2	TWD	23	VSM	-0.87	TEC	TEH	21	HOT	600UL
41	157	0.60	123	P2	TWD	23	VSM	+0.75	TEC	TEH	32	HOT	600UL
42	54	0.21	106	P2	TWD	8	VSM	+0.96	TEH	TEC	32	COLD	600UL
42	62	0.43	89	P2	TWD	13	VSM	+0.25	TEH	TEC	34	COLD	600UL
42	144	0.51	87	P2	TWD	21	VSM	+0.89	TEC	TEH	25	HOT	600UL

(de01) Post-U3C15 Inspection Results  
 MAI, MCI, MMI, MVI, SAI, SCI, SVI, TWD

QUERY: de01\_inspection\_results.qry

ROW	COL	VOLTS	DEG	CHN	IND	%TW	LOCATION	EXT	EXT	CAL #	LEG	PROBE
		0.15	159	P2	TWD 7	VSM	-0.74	TEC	TEH	25	HOT	600UL
42	148	0.41	81	P2	TWD 18	VSM	+0.25	TEC	TEH	29	HOT	600UL
42	170	0.30	76	P2	TWD 12	01H	-0.14	TEC	TEH	36	HOT	600UL
43	45	0.36	35	P3	TWD 14	DBH	+1.37	TEC	TEH	11	HOT	600UL
43	51	0.31	131	P2	TWD 14	02H	+0.75	TEH	TEC	32	COLD	600UL
43	65	0.43	108	P2	TWD 18	VSM	+0.02	TEH	TEC	34	COLD	600UL
43	107	0.34	68	P2	TWD 12	VSM	+0.19	TEH	TEC	56	COLD	600UL
		0.40	123	P2	TWD 14	VSM	+0.81	TEH	TEC	56	COLD	600UL
		0.42	76	P3	TWD 16	DBC	+1.58	TEH	TEC	56	COLD	600UL
43	119	0.33	119	P2	TWD 13	VSM	-0.83	TEH	TEC	52	COLD	600UL
		0.15	121	P2	TWD 6	VSM	+0.26	TEH	TEC	52	COLD	600UL
43	131	0.51	90	P2	TWD 22	VSM	+0.88	TEC	TEH	20	HOT	600UL
43	161	0.30	100	P2	TWD 14	VSM	-0.80	TEC	TEH	33	HOT	600UL
44	6	0.50	133	P2	TWD 22	VSM	+0.86	TEC	TEH	30	HOT	600UL
44	66	0.26	151	P2	TWD 10	VSM	+0.61	TEH	TEC	37	COLD	600UL
		0.18	127	P3	TWD 7	DBC	+1.65	TEH	TEC	37	COLD	600UL
44	72	0.30	17	P2	TWD 12	VSM	+0.84	TEH	TEC	35	COLD	600UL
		0.41	151	P3	TWD 18	DBC	+1.09	TEH	TEC	35	COLD	600UL
44	74	0.29	55	P3	TWD 14	DBH	-1.39	TEH	TEC	35	COLD	600UL
44	100	0.51	60	P3	TWD 18	DBH	-1.59	TEH	TEC	20	COLD	600UL
44	112	0.48	86	P2	TWD 20	VSM	-0.83	TEH	TEC	53	COLD	600UL
		0.38	110	P2	TWD 17	VSM	+0.06	TEH	TEC	53	COLD	600UL
		0.25	62	P2	TWD 11	VSM	+0.82	TEH	TEC	53	COLD	600UL
44	114	0.51	111	P2	TWD 21	VSM	+0.90	TEH	TEC	53	COLD	600UL
		0.51	89	P2	TWD 20	VSM	-0.91	TEH	TEC	53	COLD	600UL
44	128	0.51	144	P2	TWD 22	VSM	-0.80	TEH	TEC	49	COLD	600UL
		0.49	114	P2	TWD 21	VSM	+0.79	TEH	TEC	49	COLD	600UL
44	134	0.29	80	P2	TWD 14	VSM	-0.76	TEC	TEH	20	HOT	600UL
44	158	0.42	103	P2	TWD 18	VSM	+0.88	TEC	TEH	32	HOT	600UL
		0.35	101	P2	TWD 16	VSM	-0.69	TEC	TEH	32	HOT	600UL
45	47	0.27	107	P3	TWD 14	DBH	+1.49	TEH	TEC	33	COLD	600UL
45	119	0.52	127	P2	TWD 20	VSM	-0.83	TEH	TEC	51	COLD	600UL
		0.51	99	P2	TWD 19	VSM	+0.71	TEH	TEC	51	COLD	600UL
45	133	0.18	35	P3	TWD 9	DBC	-1.41	TEC	TEH	20	HOT	600UL
		0.34	136	P2	TWD 17	VSM	-0.66	TEC	TEH	20	HOT	600UL
45	167	0.16	153	P2	TWD 6	VSM	+0.91	TEC	TEH	36	HOT	600UL
45	169	0.39	122	P2	TWD 16	01C	+0.93	TEC	TEH	36	HOT	600UL
46	30	0.26	29	P2	TWD 11	VSM	+0.19	TEC	TEH	19	HOT	600UL
46	52	0.27	109	P3	TWD 10	DBH	+1.61	TEH	TEC	32	COLD	600UL
46	54	0.27	115	P3	TWD 10	DBH	+1.80	TEH	TEC	32	COLD	600UL
46	72	0.40	64	P2	TWD 17	VSM	+0.84	TEH	TEC	34	COLD	600UL
46	104	0.85	122	P2	TWD 26	VSM	-0.89	TEH	TEC	56	COLD	600UL
46	118	0.20	146	P2	TWD 8	VSM	-0.78	TEH	TEC	52	COLD	600UL
46	134	0.43	134	P2	TWD 19	VSM	+0.79	TEC	TEH	21	HOT	600UL

(de01) Post-U3C15 Inspection Results  
 MAI, MCI, MMI, MVI, SAI, SCI, SVI, TWD

QUERY: de01\_inspection\_results.qry

ROW	COL	VOLTS	DEG	CHN	IND	%TW	LOCATION	EXT	EXT	CAL #	LEG	PROBE
46	138	0.42	114	P2	TWD 19	04C	-0.12	TEC	TEH	25	HOT	600UL
46	146	0.55 0.57	108 83	P2 P2	TWD 22 TWD 23	VSM VSM	+0.95 -0.64	TEC TEC	TEH TEH	25 25	HOT HOT	600UL 600UL
46	164	0.24 0.28 0.40	63 94 133	P2 P2 P2	TWD 12 TWD 13 TWD 18	VSM VSM VSM	+0.88 -0.19 -0.78	TEC TEC TEC	TEH TEH TEH	37 37 37	HOT HOT HOT	600UL 600UL 600UL
46	166	0.40	97	P2	TWD 16	VSM	+0.84	TEC	TEH	36	HOT	600UL
46	170	0.28	49	P2	TWD 12	05C	+0.84	TEC	TEH	36	HOT	600UL
47	101	0.61	33	P3	TWD 23	DBC	+1.82	TEH	TEC	21	COLD	600UL
47	103	0.29 0.21 0.35	17 84 32	P3 P3 P3	TWD 13 TWD 10 TWD 15	DBH DBH DBC	-1.51 +1.99 +1.35	TEH TEH TEH	TEC TEC TEC	55 55 55	COLD COLD COLD	600UL 600UL 600UL
47	119	0.42	34	P2	TWD 15	VSM	-0.77	TEH	TEC	52	COLD	600UL
48	120	0.42 0.36	113 104	P2 P2	TWD 17 TWD 14	VSM VSM	+0.82 -0.85	TEH TEH	TEC TEC	51 51	COLD COLD	600UL 600UL
49	43	0.22	119	P2	TWD 12	08C	-1.63	TEC	TEH	10	HOT	600UL
49	47	0.22	109	P3	TWD 12	DBH	+1.09	TEH	TEC	33	COLD	600UL
49	49	0.54	148	P2	TWD 20	08H	+1.43	TEH	TEC	33	COLD	600UL
49	97	0.51	51	P3	TWD 18	DBH	+1.82	TEH	TEC	20	COLD	600UL
49	101	0.69	96	P3	TWD 23	DBH	-1.75	TEH	TEC	20	COLD	600UL
49	129	0.38	59	P2	TWD 17	08H	-1.53	TEH	TEC	49	COLD	600UL
50	18	0.63 0.23	87 157	P2 P2	TWD 24 TWD 10	VSM VSM	-0.86 +0.70	TEC TEC	TEH TEH	23 23	HOT HOT	600UL 600UL
50	20	0.41 0.60	116 94	P2 P2	TWD 20 TWD 26	VSM VSM	+0.62 +0.16	TEC TEC	TEH TEH	22 22	HOT HOT	600UL 600UL
50	74	0.23	102	P3	TWD 10	DBH	-1.88	TEH	TEC	34	COLD	600UL
50	78	0.39	53	P3	TWD 16	DBH	-1.66	TEH	TEC	17	COLD	600UL
50	98	0.46 0.57 0.07	82 81 66	P3 P3 P3	TWD 19 TWD 22 TWD 4	DBC DBH DBH	-1.78 -1.99 +2.10	TEH TEH TEH	TEC TEC TEC	21 21 21	COLD COLD COLD	600UL 600UL 600UL
50	100	0.39 0.28	66 160	P2 P2	TWD 15 TWD 12	VSM VSM	-0.76 +0.95	TEH TEH	TEC TEC	21 21	COLD COLD	600UL 600UL
51	99	0.58	120	P3	TWD 20	DBH	-1.37	TEH	TEC	20	COLD	600UL
52	76	0.40	61	P3	TWD 16	DBC	-1.58	TEH	TEC	17	COLD	600UL
52	78	0.39	15	P3	TWD 15	DBH	+1.91	TEH	TEC	16	COLD	600UL
52	80	0.48 0.22 0.12	75 153 105	P3 P3 P3	TWD 19 TWD 9 TWD 4	DBH DBC DBH	-1.54 -1.66 +2.16	TEH TEH TEH	TEC TEC TEC	17 17 17	COLD COLD COLD	600UL 600UL 600UL
52	94	0.71 0.65	125 29	P3 P3	TWD 23 TWD 22	DBC DBH	-1.59 +1.81	TEH TEH	TEC TEC	20 20	COLD COLD	600UL 600UL
52	100	0.47	35	P3	TWD 17	DBC	-1.67	TEH	TEC	20	COLD	600UL
53	47	0.30	142	P2	TWD 13	03C	+0.78	TEH	TEC	33	COLD	600UL
53	91	0.40 0.42	144 111	P3 P3	TWD 15 TWD 15	DBH DBH	-1.88 +1.97	TEH TEH	TEC TEC	20 20	COLD COLD	600UL 600UL
53	93	0.47	123	P3	TWD 19	DBH	-1.68	TEH	TEC	21	COLD	600UL
53	95	0.30	118	P3	TWD 11	DBH	+1.99	TEH	TEC	20	COLD	600UL

(de01) Post-U3C15 Inspection Results  
 MAI, MCI, MMI, MVI, SAI, SCI, SVI, TWD

QUERY: de01\_inspection\_results.qry

ROW	COL	VOLTS	DEG	CHN	IND	%TW	LOCATION	EXT	EXT	CAL #	LEG	PROBE	
		0.55	96	P3	TWD	19	DBC	-1.68	TEH	TEC	20	COLD	600UL
		0.32	146	P3	TWD	12	DBH	-1.82	TEH	TEC	20	COLD	600UL
53	97	0.43	33	P3	TWD	16	DBH	-1.07	TEH	TEC	20	COLD	600UL
53	101	0.41	62	P3	TWD	17	DBH	-1.84	TEH	TEC	21	COLD	600UL
53	107	0.38	119	P3	TWD	15	DBH	-2.19	TEH	TEC	55	COLD	600UL
54	8	0.39	113	P2	TWD	18	02C	-0.92	TEC	TEH	30	HOT	600UL
54	78	0.46	17	P3	TWD	18	DBH	-1.12	TEH	TEC	17	COLD	600UL
54	102	0.49	28	P3	TWD	18	DBC	+2.03	TEH	TEC	56	COLD	600UL
		0.34	126	P3	TWD	13	DBC	-1.88	TEH	TEC	56	COLD	600UL
55	9	0.22	61	P2	TWD	12	02C	+0.10	TEC	TEH	26	HOT	600UL
55	81	0.68	16	P3	TWD	24	DBH	+1.77	TEH	TEC	17	COLD	600UL
55	87	0.63	14	P3	TWD	21	DBH	+1.13	TEH	TEC	18	COLD	600UL
55	93	0.32	108	P3	TWD	12	DBH	+1.59	TEH	TEC	20	COLD	600UL
55	95	0.41	111	P3	TWD	17	DBH	-1.84	TEH	TEC	21	COLD	600UL
55	99	0.41	46	P3	TWD	15	DBH	-1.17	TEH	TEC	20	COLD	600UL
55	103	0.46	71	P2	TWD	16	VC3	+1.22	TEH	TEC	56	COLD	600UL
56	76	0.71	95	P2	TWD	23	VSM	+0.72	TEH	TEC	17	COLD	600UL
56	136	0.45	112	P2	TWD	21	VSM	+0.78	TEC	TEH	20	HOT	600UL
		0.58	116	P2	TWD	25	VSM	-0.72	TEC	TEH	20	HOT	600UL
57	47	0.34	108	P2	TWD	15	08H	+0.49	TEH	TEC	33	COLD	600UL
57	51	0.25	155	P2	TWD	11	08H	+0.36	TEH	TEC	33	COLD	600UL
		0.29	91	P2	TWD	13	08H	+0.82	TEH	TEC	33	COLD	600UL
57	79	0.49	88	P3	TWD	19	DBH	+1.85	TEH	TEC	17	COLD	600UL
57	89	0.22	160	P3	TWD	12	DBH	-2.21	TEH	TEC	19	COLD	600UL
57	129	0.26	142	P3	TWD	11	DBH	-0.45	TEH	TEC	50	COLD	600UL
57	143	0.79	106	P2	TWD	28	VH3	+0.78	TEC	TEH	24	HOT	600UL
58	92	0.30	25	P3	TWD	12	DBH	-1.21	TEH	TEC	20	COLD	600UL
58	148	0.48	77	P2	TWD	21	VSM	+0.87	TEC	TEH	29	HOT	600UL
		0.24	144	P2	TWD	12	VH3	-0.85	TEC	TEH	29	HOT	600UL
		0.57	126	P2	TWD	23	VC3	-0.85	TEC	TEH	29	HOT	600UL
59	33	0.35	150	P2	TWD	17	VH3	-0.86	TEC	TEH	14	HOT	600UL
59	97	0.22	144	P3	TWD	10	DBC	-1.67	TEH	TEC	21	COLD	600UL
60	48	0.79	91	P2	TWD	26	08H	-0.93	TEH	TEC	33	COLD	600UL
60	50	0.40	68	P2	TWD	16	08H	-0.34	TEH	TEC	33	COLD	600UL
60	94	0.20	128	P3	TWD	9	DBH	-1.90	TEH	TEC	21	COLD	600UL
		0.41	11	P3	TWD	17	DBH	+2.00	TEH	TEC	21	COLD	600UL
60	164	0.22	149	P2	TWD	11	08C	+0.86	TEC	TEH	33	HOT	600UL
61	79	0.44	36	P3	TWD	18	DBH	+1.89	TEH	TEC	17	COLD	600UL
61	91	0.38	97	P2	TWD	14	03H	+0.10	TEH	TEC	21	COLD	600UL
61	99	0.32	147	P2	TWD	13	VSM	+0.89	TEH	TEC	21	COLD	600UL
		0.25	121	P2	TWD	11	VH3	-0.87	TEH	TEC	21	COLD	600UL
		0.27	59	P2	TWD	11	VH3	+0.74	TEH	TEC	21	COLD	600UL
		0.06	140	P2	TWD	3	VH3	-0.13	TEH	TEC	21	COLD	600UL

(de01) Post-U3C15 Inspection Results  
 MAI, MCI, MMI, MVI, SAI, SCI, SVI, TWD

QUERY: de01\_inspection\_results.gry

ROW	COL	VOLTS	DEG	CHN	IND	%TW	LOCATION		EXT	EXT	CAL #	LEG	PROBE
62	50	0.75	83	P2	TWD	26	08H	-0.13	TEH	TEC	32	COLD	600UL
62	78	0.42	26	P3	TWD	17	DBH	+2.06	TEH	TEC	17	COLD	600UL
62	166	0.41	97	P2	TWD	17	02H	-0.82	TEC	TEH	36	HOT	600UL
		0.34	104	P2	TWD	14	02H	-0.20	TEC	TEH	36	HOT	600UL
63	53	0.54	103	P2	TWD	21	08H	+0.48	TEH	TEC	32	COLD	600UL
63	85	0.27	129	P3	TWD	11	DBH	+1.58	TEH	TEC	16	COLD	600UL
63	89	0.55	21	2	SAI		TSH	-1.33	TSH	TSH	86	HOT	580PP
		0.39	19	2	SAI		TSH	-1.65	TSH	TSH	86	HOT	580PP
64	44	0.30	116	P2	TWD	15	VC3	+0.82	TEC	TEH	10	HOT	600UL
64	96	0.28	34	P3	TWD	11	DBC	+1.30	TEH	TEC	20	COLD	600UL
64	166	0.25	21	P2	TWD	10	07H	+0.70	TEC	TEH	36	HOT	600UL
65	49	0.58	153	P2	TWD	21	VH3	-0.78	TEH	TEC	33	COLD	600UL
		0.25	158	P2	TWD	11	VH3	+0.82	TEH	TEC	33	COLD	600UL
65	53	0.35	77	P2	TWD	15	08H	-0.62	TEH	TEC	33	COLD	600UL
		0.30	95	P2	TWD	13	08H	-0.15	TEH	TEC	33	COLD	600UL
65	59	0.85	118	P2	TWD	28	VSM	-0.79	TEH	TEC	34	COLD	600UL
		0.42	138	P2	TWD	18	VSM	+0.81	TEH	TEC	34	COLD	600UL
65	87	0.66	106	P3	TWD	26	DBH	+1.70	TEH	TEC	19	COLD	600UL
65	97	0.29	132	P3	TWD	11	DBC	-1.90	TEH	TEC	20	COLD	600UL
65	151	0.32	95	P2	TWD	16	VSM	+0.88	TEC	TEH	28	HOT	600UL
		0.41	37	P2	TWD	19	VSM	-0.80	TEC	TEH	28	HOT	600UL
		0.19	37	P2	TWD	10	VSM	+0.16	TEC	TEH	28	HOT	600UL
66	76	0.19	95	2	SAI		TSH	+0.70	TSH	TSH	86	HOT	580PP
		0.10	101	2	SAI		TSH	+0.66	TSH	TSH	86	HOT	580PP
66	82	0.30	32	P3	TWD	13	DBH	-1.68	TEH	TEC	17	COLD	600UL
		0.31	121	P2	TWD	12	VH3	+0.88	TEH	TEC	17	COLD	600UL
66	96	0.27	135	P3	TWD	12	DBH	-2.05	TEH	TEC	21	COLD	600UL
66	98	0.50	144	P3	TWD	20	DBH	-1.31	TEH	TEC	21	COLD	600UL
67	55	0.31	121	P2	TWD	14	08H	+0.75	TEH	TEC	34	COLD	600UL
67	87	0.68	164	P3	TWD	23	DBH	+1.32	TEH	TEC	18	COLD	600UL
		0.36	60	P3	TWD	13	DBC	-1.77	TEH	TEC	18	COLD	600UL
67	165	0.62	84	P2	TWD	23	01C	-0.16	TEC	TEH	36	HOT	600UL
		0.22	139	P2	TWD	9	01C	+0.90	TEC	TEH	36	HOT	600UL
68	12	0.42	119	P2	TWD	19	02C	+0.00	TEC	TEH	27	HOT	600UL
68	54	0.38	118	P2	TWD	16	08H	+0.38	TEH	TEC	34	COLD	600UL
68	88	0.48	108	P3	TWD	22	DBH	-1.70	TEH	TEC	19	COLD	600UL
68	92	0.40	152	P3	TWD	15	DBH	-1.61	TEH	TEC	20	COLD	600UL
68	132	0.78	88	P2	TWD	29	VC3	+0.87	TEC	TEH	20	HOT	600UL
68	164	0.23	109	P2	TWD	11	01C	-0.06	TEC	TEH	33	HOT	600UL
		0.39	110	P2	TWD	18	01C	+0.97	TEC	TEH	33	HOT	600UL
69	39	0.31	93	P2	TWD	15	VH3	-0.88	TEC	TEH	10	HOT	600UL
69	55	0.41	145	P2	TWD	16	08H	+0.80	TEH	TEC	35	COLD	600UL
69	65	0.49	121	P2	TWD	16	VC3	-0.76	TEH	TEC	37	COLD	600UL
		0.37	36	P2	TWD	14	VC3	+0.17	TEH	TEC	37	COLD	600UL
69	127	0.27	85	P2	TWD	13	VSM	+0.86	TEH	TEC	49	COLD	600UL



(de01) Post-U3C15 Inspection Results  
 MAI, MCI, MMI, MVI, SAI, SCI, SVI, TWD

QUERY: de01\_inspection\_results.qry

ROW	COL	VOLTS	DEG	CHN	IND	TW	LOCATION	EXT	EXT	CAL #	LEG	PROBE	
		0.37	107	P2	TWD	17	VC3	-0.79	TEH	TEC	49	COLD	600UL
70	56	0.30	121	P2	TWD	14	08H	+0.69	TEH	TEC	34	COLD	600UL
70	80	0.45	73	P2	TWD	17	VH3	-0.86	TEH	TEC	17	COLD	600UL
70	86	0.24	48	P3	TWD	10	DBC	+1.49	TEH	TEC	17	COLD	600UL
70	92	0.32	81	P3	TWD	14	DBH	-1.58	TEH	TEC	21	COLD	600UL
71	19	0.31	149	P3	TWD	13	DBH	+1.97	TEC	TEH	23	HOT	600UL
71	53	0.37	44	P2	TWD	16	08H	+0.42	TEH	TEC	32	COLD	600UL
71	65	0.37	124	P2	TWD	15	VH3	+0.83	TEH	TEC	36	COLD	600UL
71	75	0.37	156	P2	TWD	16	VH3	+0.84	TEH	TEC	38	COLD	600UL
71	133	0.72	140	P2	TWD	28	VH3	+0.66	TEC	TEH	20	HOT	600UL
		0.61	142	P2	TWD	25	VC3	-0.82	TEC	TEH	20	HOT	600UL
		0.67	81	P2	TWD	27	VH3	-0.74	TEC	TEH	20	HOT	600UL
71	163	0.22	77	P2	TWD	11	02C	+0.10	TEC	TEH	33	HOT	600UL
72	84	0.76	100	P2	TWD	25	VSM	-0.78	TEH	TEC	17	COLD	600UL
		0.26	143	P2	TWD	10	VSM	+0.90	TEH	TEC	17	COLD	600UL
		0.45	153	P2	TWD	17	VC3	-0.10	TEH	TEC	17	COLD	600UL
		0.55	73	P2	TWD	19	VC3	+0.76	TEH	TEC	17	COLD	600UL
73	53	0.35	26	P2	TWD	15	08H	+0.55	TEH	TEC	33	COLD	600UL
73	95	0.34	4	P3	TWD	15	DBC	+2.07	TEH	TEC	21	COLD	600UL
73	157	0.27	76	P2	TWD	13	VC3	+0.94	TEC	TEH	32	HOT	600UL
74	42	0.30	66	P2	TWD	13	VH3	+0.06	TEC	TEH	11	HOT	600UL
		0.47	83	P2	TWD	19	VH3	+0.70	TEC	TEH	11	HOT	600UL
74	110	0.49	41	P2	TWD	18	03H	-0.17	TEH	TEC	54	COLD	600UL
74	118	0.29	92	P2	TWD	12	VSM	-0.77	TEH	TEC	52	COLD	600UL
74	140	0.33	113	P2	TWD	15	VC3	+0.79	TEC	TEH	25	HOT	600UL
75	19	0.26	54	P2	TWD	12	VSM	-0.70	TEC	TEH	23	HOT	600UL
		0.76	135	P2	TWD	27	VC3	+0.78	TEC	TEH	23	HOT	600UL
75	43	0.84	101	P2	TWD	29	VC3	+0.81	TEC	TEH	11	HOT	600UL
75	45	0.43	144	P2	TWD	18	VH3	-0.80	TEC	TEH	11	HOT	600UL
75	79	0.29	152	P2	TWD	12	VSM	-0.87	TEH	TEC	16	COLD	600UL
		0.71	143	P2	TWD	24	VSM	+0.85	TEH	TEC	16	COLD	600UL
75	95	0.94	73	P2	TWD	29	VC3	-0.84	TEH	TEC	20	COLD	600UL
		0.22	22	P2	TWD	10	VC3	+0.58	TEH	TEC	20	COLD	600UL
		0.31	25	P3	TWD	12	DBC	+1.89	TEH	TEC	20	COLD	600UL
75	147	0.66	112	P2	TWD	25	VC3	+0.73	TEC	TEH	28	HOT	600UL
75	157	0.51	5	P3	TWD	20	DBC	+1.61	TEC	TEH	33	HOT	600UL
76	16	0.41	104	P2	TWD	17	08C	+0.00	TEC	TEH	23	HOT	600UL
76	54	0.20	156	P3	TWD	8	DBH	+0.84	TEH	TEC	34	COLD	600UL
76	132	0.43	132	P2	TWD	20	VH3	-0.80	TEC	TEH	20	HOT	600UL
		0.34	91	P2	TWD	17	VC3	+0.80	TEC	TEH	20	HOT	600UL
76	134	0.28	157	P3	TWD	13	DBC	-1.54	TEC	TEH	20	HOT	600UL
76	146	0.60	38	P2	TWD	24	VH3	+0.72	TEC	TEH	24	HOT	600UL
		0.61	136	P2	TWD	24	VH3	-0.94	TEC	TEH	24	HOT	600UL
76	152	0.34	82	P2	TWD	16	VC3	-0.72	TEC	TEH	28	HOT	600UL

(de01) Post-U3C15 Inspection Results  
 MAI, MCI, MMI, MVI, SAI, SCI, SVI, TWD

QUERY: de01\_inspection\_results.qry

ROW	COL	VOLTS	DEG	CHN	IND	TW	LOCATION	EXT	EXT	CAL #	LEG	PROBE
76	162	0.27	50	P2	TWD	13	08H +0.76	TEC	TEH	32	HOT	600UL
77	29	0.62	143	P2	TWD	26	VC3 +0.78	TEC	TEH	18	HOT	600UL
77	39	0.32	102	P2	TWD	16	VC3 +0.90	TEC	TEH	10	HOT	600UL
77	61	0.62	114	P2	TWD	21	VH3 -0.86	TEH	TEC	29	COLD	600UL
		0.71	148	P2	TWD	23	VSM +0.70	TEH	TEC	29	COLD	600UL
77	75	0.40	38	P2	TWD	16	VH3 -0.96	TEH	TEC	39	COLD	600UL
		0.26	42	P3	TWD	12	DBC +2.09	TEH	TEC	39	COLD	600UL
77	135	0.34	75	P2	TWD	17	VSM -0.97	TEC	TEH	20	HOT	600UL
		0.30	76	P2	TWD	15	VH3 +0.82	TEC	TEH	20	HOT	600UL
77	155	0.39	141	P2	TWD	17	VH3 -0.83	TEC	TEH	32	HOT	600UL
		0.84	129	P2	TWD	28	VH3 +0.79	TEC	TEH	32	HOT	600UL
78	16	0.29	75	P2	TWD	16	05C +0.80	TEC	TEH	22	HOT	600UL
78	24	0.57	95	P2	TWD	22	VC3 -1.01	TEC	TEH	19	HOT	600UL
78	40	0.23	18	P3	TWD	10	DBC -1.63	TEC	TEH	11	HOT	600UL
78	62	0.49	105	P2	TWD	19	VC3 -0.60	TEH	TEC	28	COLD	600UL
78	138	0.23	125	P2	TWD	11	VH3 -0.92	TEC	TEH	25	HOT	600UL
79	25	0.36	49	P2	TWD	18	08C -0.98	TEC	TEH	18	HOT	600UL
79	29	0.37	147	P2	TWD	19	VSM -0.74	TEC	TEH	18	HOT	600UL
		0.38	45	P2	TWD	19	VC3 +0.76	TEC	TEH	18	HOT	600UL
79	39	0.41	104	P3	TWD	19	DBC +1.77	TEC	TEH	10	HOT	600UL
79	61	0.37	93	P2	TWD	14	VH3 -0.86	TEH	TEC	29	COLD	600UL
79	95	0.25	5	P3	TWD	12	DBC +1.75	TEH	TEC	17	COLD	600UL
79	157	0.32	143	P2	TWD	14	01H +0.84	TEC	TEH	32	HOT	600UL
79	159	0.25	24	P3	TWD	12	DBC +1.91	TEC	TEH	32	HOT	600UL
80	64	0.24	170	P3	TWD	9	DBH +1.19	TEH	TEC	28	COLD	600UL
80	112	0.29	15	P3	TWD	12	DBH +1.61	TEH	TEC	53	COLD	600UL
80	152	0.31	20	P3	TWD	15	DBC +1.42	TEC	TEH	28	HOT	600UL
81	27	0.23	97	P3	TWD	12	DBH -1.85	TEC	TEH	1	HOT	600UL
81	29	0.40	127	P2	TWD	13	VH3 +0.81	TEC	TEH	1	HOT	600UL
81	51	0.22	174	P3	TWD	8	DBH +2.05	TEH	TEC	25	COLD	600UL
81	61	0.17	64	P2	TWD	6	VH3 -0.76	TEH	TEC	27	COLD	600UL
81	153	0.46	117	P2	TWD	21	VH3 +0.91	TEC	TEH	17	HOT	600UL
		0.33	6	P3	TWD	15	DBC +1.43	TEC	TEH	17	HOT	600UL
82	18	0.35	123	P2	TWD	17	08C +0.74	TEC	TEH	1	HOT	600UL
82	64	0.67	99	P2	TWD	24	VH3 +0.96	TEH	TEC	26	COLD	600UL
92	94	0.38	138	P2	TWD	15	VH3 -0.04	TEH	TEC	6	COLD	600UL
83	17	0.45	79	P2	TWD	19	02C +0.94	TEC	TEH	2	HOT	600UL
		0.50	100	P2	TWD	21	08H +0.81	TEC	TEH	2	HOT	600UL
		0.14	120	P2	TWD	7	08H -1.09	TEC	TEH	2	HOT	600UL
83	59	0.30	17	P3	TWD	12	DBH +2.02	TEH	TEC	27	COLD	600UL
83	73	0.33	99	P3	TWD	14	DBH +1.66	TEH	TEC	21	COLD	600UL
83	101	0.29	91	P2	TWD	12	VSM +1.25	TEH	TEC	6	COLD	600UL

(de01) Post-U3C15 Inspection Results  
 MAI, MCI, MMI, MVI, SAI, SCI, SVI, TWD

QUERY: de01\_inspection\_results.qry

ROW	COL	VOLTS	DEG	CHN	IND	TW	LOCATION		EXT	EXT	CAL #	LEG	PROBE
83	103	0.60	110	P2	TWD	22	09H	+1.52	TEH	TEC	6	COLD	600UL
83	107	0.32	125	P2	TWD	13	09H	-1.21	TEH	TEC	6	COLD	600UL
83	115	0.59	122	P2	TWD	20	VSM	+1.24	TEH	TEC	3	COLD	600UL
		0.77	122	P2	TWD	24	09H	+1.67	TEH	TEC	3	COLD	600UL
84	24	0.38	7	P3	TWD	18	DBC	+1.66	TEC	TEH	1	HOT	600UL
84	32	0.20	21	P3	TWD	11	DBH	-1.78	TEC	TEH	1	HOT	600UL
84	60	0.15	81	P3	TWD	8	DBH	+0.92	TEH	TEC	26	COLD	600UL
84	126	0.51	168	P2	TWD	21	VH2	-0.91	TEH	TEC	1	COLD	600UL
85	31	0.20	27	P3	TWD	11	DBH	-1.82	TEC	TEH	1	HOT	600UL
86	66	0.55	119	P2	TWD	21	09H	+0.19	TEH	TEC	26	COLD	600UL
		0.47	74	P2	TWD	18	VSM	-0.81	TEH	TEC	26	COLD	600UL
86	76	0.25	105	P2	TWD	11	07H	+0.17	TEH	TEC	8	COLD	600UL
86	80	0.38	52	P2	TWD	17	09H	+0.21	TEH	TEC	7	COLD	600UL
86	144	0.53	49	P2	TWD	23	VH2	+0.79	TEC	TEH	17	HOT	600UL
86	156	0.52	67	P2	TWD	23	VH2	-0.71	TEC	TEH	17	HOT	600UL
87	103	0.48	89	P2	TWD	18	08H	+0.74	TEH	TEC	6	COLD	600UL
		0.46	137	P2	TWD	18	09H	+0.76	TEH	TEC	6	COLD	600UL
87	105	0.22	154	P2	TWD	10	08H	+0.55	TEH	TEC	6	COLD	600UL
87	157	0.46	143	P2	TWD	21	03H	-1.23	TEC	TEH	16	HOT	600UL
88	46	0.29	104	P3	TWD	15	DBC	-1.63	TEC	TEH	5	HOT	600UL
88	66	0.36	99	P2	TWD	15	09H	+0.85	TEH	TEC	26	COLD	600UL
88	102	0.49	80	P2	TWD	20	VH2	-0.81	TEH	TEC	5	COLD	600UL
88	104	0.14	133	P2	TWD	6	08H	-0.94	TEH	TEC	5	COLD	600UL
		0.30	67	P2	TWD	13	08H	-0.10	TEH	TEC	5	COLD	600UL
88	116	0.67	135	P2	TWD	23	VH2	-0.69	TEH	TEC	4	COLD	600UL
89	71	0.28	129	P2	TWD	11	09H	+0.46	TEH	TEC	23	COLD	600UL
89	73	0.19	148	P3	TWD	8	DBH	-1.05	TEH	TEC	23	COLD	600UL
89	101	0.27	27	P2	TWD	13	08H	+0.71	TEH	TEC	5	COLD	600UL
89	121	0.41	89	P2	TWD	16	VH2	+0.66	TEH	TEC	4	COLD	600UL
89	131	0.34	53	P2	TWD	14	VH2	+1.13	TEC	TEH	7	HOT	600UL
89	137	0.53	130	P2	TWD	22	VH2	+0.87	TEC	TEH	8	HOT	600UL
		0.50	100	P2	TWD	21	VH2	-0.96	TEC	TEH	8	HOT	600UL
		0.51	111	P3	TWD	22	DBH	+1.58	TEC	TEH	8	HOT	600UL
90	68	0.27	110	P2	TWD	12	09H	+0.60	TEH	TEC	28	COLD	600UL
91	67	0.28	152	P2	TWD	11	VH3	-0.80	TEH	TEC	29	COLD	600UL
91	137	0.22	38	P3	TWD	12	DBH	+2.18	TEC	TEH	8	HOT	600UL
93	87	0.36	64	P2	TWD	16	07H	+0.92	TEH	TEC	10	COLD	600UL
		0.61	149	P2	TWD	23	08H	+0.79	TEH	TEC	10	COLD	600UL
94	106	0.49	81	P2	TWD	19	VH2	-1.01	TEH	TEC	6	COLD	600UL
96	24	0.58	98	P2	TWD	24	09C	+0.83	TEC	TEH	1	HOT	600UL
97	27	0.12	156	P3	TWD	7	DBC	-1.75	TEC	TEH	1	HOT	600UL
97	53	0.69	64	P2	TWD	21	VH2	+0.84	TEH	TEC	25	COLD	600UL

(de01) Post-U3C15 Inspection Results  
 MAI, MCI, MMI, MVI, SAI, SCI, SVI, TWD

QUERY: de01\_inspection\_results.qry

ROW	COL	VOLTS	DEG	CHN	IND	TW	LOCATION	EXT	EXT	CAL #	LEG	PROBE	
		0.40	45	P2	TWD	13	VH2	+0.23	TEH	TEC	25	COLD	600UL
		0.38	158	P2	TWD	13	VH3	-0.89	TEH	TEC	25	COLD	600UL
97	71	0.10	164	P3	TWD	4	DBH	+1.57	TEH	TEC	23	COLD	600UL
97	89	0.25	159	P3	TWD	10	DBH	+0.33	TEH	TEC	10	COLD	600UL
97	99	0.18	161	P3	TWD	10	DBH	+0.00	TEH	TEC	5	COLD	600UL
98	24	0.42	149	P2	TWD	18	04H	-1.02	TEC	TEH	2	HOT	600UL
98	144	0.28	108	P2	TWD	14	09H	-0.83	TEC	TEH	17	HOT	600UL
99	121	0.41	111	P2	TWD	16	VH2	-0.76	TEH	TEC	4	COLD	600UL
99	151	0.49	136	P2	TWD	22	08H	-0.68	TEC	TEH	16	HOT	600UL
100	42	0.32	52	P2	TWD	14	VH2	-0.93	TEC	TEH	6	HOT	600UL
100	90	0.29	59	P3	TWD	8	DBH	-1.69	TEH	TEC	15	COLD	600UL
101	69	0.93	28	P1	SCI		TSH	-0.11	TSH	TSH	84	HOT	580PP
101	123	0.29	119	P2	TWD	12	VH2	+0.97	TEH	TEC	2	COLD	600UL
102	44	0.16	24	P3	TWD	8	DBH	+1.43	TEC	TEH	6	HOT	600UL
102	124	0.65	119	P2	TWD	23	VH2	-0.95	TEH	TEC	2	COLD	600UL
102	150	0.25	147	P3	TWD	12	DBC	+1.59	TEC	TEH	16	HOT	600UL
103	29	0.56	106	P2	TWD	22	VH2	+0.75	TEC	TEH	2	HOT	600UL
		0.54	77	P2	TWD	22	VH2	-0.83	TEC	TEH	2	HOT	600UL
103	69	0.69	18	P1	SCI		TSH	-0.09	TSH	TSH	85	HOT	580PP
		0.68	16	P1	SCI		TSH	-0.07	TSH	TSH	85	HOT	580PP
103	119	0.33	149	P3	TWD	14	DBH	+1.71	TEH	TEC	3	COLD	600UL
103	149	0.53	135	P2	TWD	23	08H	-0.06	TEC	TEH	16	HOT	600UL
104	116	0.57	126	P2	TWD	21	VH2	-0.80	TEH	TEC	4	COLD	600UL
104	120	0.35	124	P2	TWD	16	VH2	-0.76	TEH	TEC	3	COLD	600UL
105	33	0.42	127	P2	TWD	18	VH2	+0.93	TEC	TEH	2	HOT	600UL
105	117	0.24	110	P3	TWD	10	DBH	+1.28	TEH	TEC	4	COLD	600UL
106	28	0.34	138	P3	TWD	15	DBH	+1.56	TEC	TEH	2	HOT	600UL
106	30	0.32	115	P2	TWD	16	09H	+0.97	TEC	TEH	1	HOT	600UL
106	46	0.27	102	P2	TWD	12	VH3	-0.95	TEC	TEH	6	HOT	600UL
106	110	0.39	102	P3	TWD	15	DBH	-1.40	TEH	TEC	12	COLD	600UL
106	112	0.42	134	P2	TWD	18	VH2	-0.87	TEH	TEC	12	COLD	600UL
		0.39	72	P2	TWD	17	VH2	+0.95	TEH	TEC	12	COLD	600UL
107	31	0.27	131	P3	TWD	12	DBH	-1.62	TEC	TEH	2	HOT	600UL
107	45	0.76	46	P2	TWD	26	VH2	+0.35	TEC	TEH	6	HOT	600UL
		0.64	67	P2	TWD	23	VH2	-0.35	TEC	TEH	6	HOT	600UL
107	55	0.34	24	P2	TWD	12	08C	+0.88	TEH	TEC	25	COLD	600UL
107	121	0.54	36	P2	TWD	20	VH2	-0.93	TEH	TEC	4	COLD	600UL
		0.94	154	P2	TWD	29	VH2	+0.93	TEH	TEC	4	COLD	600UL
107	123	0.13	106	P3	TWD	8	DBH	-0.31	TEH	TEC	1	COLD	600UL
107	125	0.42	56	P2	TWD	18	VH2	+0.87	TEH	TEC	1	COLD	600UL
107	139	0.48	100	P2	TWD	20	09H	+0.60	TEC	TEH	12	HOT	600UL

(de01) Post-U3C15 Inspection Results  
 MAI, MCI, MMI, MVI, SAI, SCI, SVI, TWD

QUERY: de01\_inspection\_results.cry

ROW	COL	VOLTS	DEG	CHN	IND	%TW	LOCATION		EXT	EXT	CAL #	LEG	PROBE
107	145	0.61	113	P2	TWD	25	08H	-0.83	TEC	TEH	16	HOT	600UL
108	48	0.44	138	P2	TWD	18	VH2	-0.81	TEH	TEC	22	COLD	600UL
108	50	0.43	137	P2	TWD	18	VH2	+0.96	TEH	TEC	22	COLD	600UL
108	58	0.42	80	P2	TWD	17	VC3	+0.89	TEH	TEC	24	COLD	600UL
108	82	0.30	155	P2	TWD	11	03C	-1.05	TEH	TEC	9	COLD	600UL
108	138	0.27	122	P2	TWD	12	08H	-0.93	TEC	TEH	12	HOT	600UL
108	144	0.44	141	P2	TWD	20	07H	+0.76	TEC	TEH	16	HOT	600UL
109	39	0.18	67	P3	TWD	9	DBC	-1.53	TEC	TEH	5	HOT	600UL
109	117	0.50	49	P2	TWD	19	09H	-1.13	TEH	TEC	4	COLD	600UL
109	127	0.17	144	P3	TWD	8	DBC	-1.83	TEH	TEC	2	COLD	600UL
109	137	0.21	145	P2	TWD	10	08H	+1.06	TEC	TEH	8	HOT	600UL
		0.70	79	P2	TWD	26	08H	-0.93	TEC	TEH	8	HOT	600UL
109	139	0.20	55	P3	TWD	8	DBC	-1.66	TEC	TEH	13	HOT	600UL
		0.23	4	P3	TWD	10	DBH	+1.50	TEC	TEH	13	HOT	600UL
110	32	0.15	38	P3	TWD	8	DBH	+1.57	TEC	TEH	2	HOT	600UL
110	34	0.27	39	P2	TWD	13	07H	+0.29	TEC	TEH	1	HOT	600UL
110	44	0.35	122	P2	TWD	15	VH2	-0.66	TEC	TEH	6	HOT	600UL
110	52	0.48	129	P2	TWD	19	VH2	-1.00	TEH	TEC	24	COLD	600UL
110	122	0.71	127	P2	TWD	24	VH2	+0.00	TEH	TEC	2	COLD	600UL
110	136	0.38	134	P2	TWD	17	08H	+0.99	TEC	TEH	8	HOT	600UL
		0.40	62	P2	TWD	18	08H	-0.93	TEC	TEH	8	HOT	600UL
110	138	0.23	85	P2	TWD	12	08H	+0.10	TEC	TEH	13	HOT	600UL
111	37	0.32	17	P3	TWD	14	DBC	+2.03	TEC	TEH	6	HOT	600UL
111	47	0.27	122	P2	TWD	11	08C	+0.91	TEH	TEC	23	COLD	600UL
111	113	0.46	120	P2	TWD	20	VH2	-0.90	TEH	TEC	12	COLD	600UL
		0.47	128	P2	TWD	20	VH2	+0.90	TEH	TEC	12	COLD	600UL
111	131	0.27	100	P2	TWD	13	08H	+0.80	TEC	TEH	3	HOT	600UL
		0.22	81	P2	TWD	11	08H	-0.75	TEC	TEH	3	HOT	600UL
111	133	0.37	130	P2	TWD	17	08H	-0.02	TEC	TEH	7	HOT	600UL
		0.37	130	P2	TWD	15	08H	+0.79	TEC	TEH	7	HOT	600UL
111	135	0.33	60	P2	TWD	15	VH2	+0.25	TEC	TEH	8	HOT	600UL
		0.35	105	P2	TWD	16	07H	+0.79	TEC	TEH	8	HOT	600UL
111	137	0.85	124	P2	TWD	29	VH2	+0.83	TEC	TEH	8	HOT	600UL
111	141	0.36	81	P3	TWD	17	DBH	-1.84	TEC	TEH	16	HOT	600UL
111	143	0.30	84	P2	TWD	15	VC3	+0.87	TEC	TEH	16	HOT	600UL
		0.18	103	P2	TWD	10	VC3	-0.79	TEC	TEH	16	HOT	600UL
		0.43	155	P3	TWD	19	DBH	+1.49	TEC	TEH	16	HOT	600UL
112	40	0.32	31	P3	TWD	16	DBH	+1.63	TEC	TEH	5	HOT	600UL
112	124	0.78	110	P2	TWD	25	VH2	-1.06	TEH	TEC	2	COLD	600UL
112	132	0.64	83	P2	TWD	24	07H	+0.85	TEC	TEH	7	HOT	600UL
		0.51	123	P2	TWD	20	08H	+0.88	TEC	TEH	7	HOT	600UL
		0.55	80	P2	TWD	22	VH2	+0.83	TEC	TEH	7	HOT	600UL
112	142	0.37	8	P3	TWD	17	DBC	+1.86	TEC	TEH	16	HOT	600UL
		0.45	158	P2	TWD	20	VC2	-0.87	TEC	TEH	16	HOT	600UL

(de01) Post-U3C15 Inspection Results  
 MAI, MCI, MMI, MVI, SAI, SCI, SVI, TWD

QUERY: de01\_inspection\_results.qry

ROW	COL	VOLTS	DEG	CHN	IND	%TW	LOCATION	EXT	EXT	CAL #	LEG	PROBE	
113	67	0.57	89	P2	TWD	20	04C	+0.27	TEH	TEC	29	COLD	600UL
113	99	0.78 0.51	19 15	2 2	SAI SAI		TSH TSH	-7.78 -7.52	TSH TSH	TSH TSH	106 106	HOT HOT	580PP 580PP
113	129	0.46 0.51 0.37	41 123 93	P2 P2 P3	TWD TWD TWD	17 19 17	09H VH2 DBH	+0.83 +0.89 +2.18	TEH TEH TEH	TEC TEC TEC	2 2 2	COLD COLD COLD	600UL 600UL 600UL
114	90	0.24	138	P3	TWD	8	DBH	+1.38	TEH	TEC	14	COLD	600UL
114	104	0.53	123	P2	TWD	19	VH2	-0.87	TEH	TEC	13	COLD	600UL
114	106	0.35	29	P3	TWD	13	DBH	+1.89	TEH	TEC	12	COLD	600UL
114	114	0.76 0.40	59 133	P2 P2	TWD TWD	27 17	VH2 VH2	-0.88 +0.90	TEH TEH	TEC TEC	12 12	COLD COLD	600UL 600UL
114	130	0.33 0.32	92 137	P2 P2	TWD TWD	16 16	09H 09H	-0.98 +0.02	TEC TEC	TEH TEH	3 3	HOT HOT	600UL 600UL
114	132	0.93	128	P2	TWD	30	07H	+0.81	TEC	TEH	7	HOT	600UL
115	41	0.30 0.30	140 46	P2 P2	TWD TWD	13 14	VH1 VH1	+0.91 -0.62	TEC TEC	TEH TEH	6 6	HOT HOT	600UL 600UL
115	45	0.68	138	P2	TWD	24	VH1	-1.12	TEC	TEH	6	HOT	600UL
115	105	0.51	68	P2	TWD	21	VH2	+1.02	TEH	TEC	12	COLD	600UL
115	127	0.41	145	P2	TWD	18	09H	+0.79	TEH	TEC	1	COLD	600UL
115	129	0.36	108	P2	TWD	16	09H	-0.72	TEH	TEC	1	COLD	600UL
116	124	0.43 0.24 0.33	117 131 101	P2 P2 P2	TWD TWD TWD	17 10 13	08H 08H 09H	+0.89 +0.46 +0.78	TEH TEH TEH	TEC TEC TEC	2 2 2	COLD COLD COLD	600UL 600UL 600UL
116	126	0.31	78	P2	TWD	15	08H	+0.95	TEH	TEC	1	COLD	600UL
116	128	0.32 0.52 0.29 0.25	116 92 92 141	P2 P2 P2 P2	TWD TWD TWD TWD	13 19 12 10	08H 09H 08H 09H	+0.79 +0.68 +0.28 -0.39	TEH TEH TEH TEH	TEC TEC TEC TEC	2 2 2 2	COLD COLD COLD COLD	600UL 600UL 600UL 600UL
117	123	0.62 0.40	121 60	P2 P2	TWD TWD	22 16	08H 06H	+0.89 +0.83	TEH TEH	TEC TEC	2 2	COLD COLD	600UL 600UL
117	125	0.19 0.24	44 130	P2 P2	TWD TWD	8 10	09H 09H	-0.80 +0.42	TEH TEH	TEC TEC	2 2	COLD COLD	600UL 600UL
117	129	0.27	90	P2	TWD	13	08H	+1.08	TEH	TEC	1	COLD	600UL
118	46	0.15 0.40	150 130	P2 P2	TWD TWD	8 17	VH1 VH1	+0.74 -0.33	TEC TEC	TEH TEH	5 5	HOT HOT	600UL 600UL
118	92	0.26	58	P2	TWD	10	VH1	+1.05	TEH	TEC	14	COLD	600UL
119	123	0.59	55	P2	TWD	23	09H	+0.83	TEH	TEC	1	COLD	600UL
119	125	0.46 0.21	115 52	P2 P2	TWD TWD	20 11	09H 09H	-1.04 -0.04	TEH TEH	TEC TEC	1 1	COLD COLD	600UL 600UL
119	139	0.64	126	P2	TWD	24	10C	-1.20	TEC	TEH	12	HOT	600UL
120	62	0.47 0.40	80 147	P2 P2	TWD TWD	19 17	VH1 VH2	-0.75 -0.81	TEH TEH	TEC TEC	26 26	COLD COLD	600UL 600UL
120	80	0.28	50	P3	TWD	11	DBH	+1.79	TEH	TEC	7	COLD	600UL
120	92	0.45	113	P2	TWD	15	VH1	+0.81	TEH	TEC	15	COLD	600UL
120	112	0.25	58	P3	TWD	10	DBH	-0.04	TEH	TEC	13	COLD	600UL
121	107	0.36	103	P3	TWD	15	DBH	+1.72	TEH	TEC	13	COLD	600UL

(de01) Post-U3C15 Inspection Results  
MAI, MCI, MMI, MVI, SAI, SCI, SVI, TWD

QUERY: de01\_inspection\_results.qry

ROW	COL	VOLTS	DEG	CHN	IND	%TW	LOCATION		EXT	EXT	CAL	#	LEG	PROBE
121	113	0.28	111	P2	TWD 11		VH1	-0.81	TEH	TEC	13		COLD	600UL
121	117	0.33	92	P2	TWD 13		VH1	+0.71	TEH	TEC	4		COLD	600UL
121	121	0.45	109	P2	TWD 19		09H	+0.51	TEH	TEC	3		COLD	600UL
		0.54	110	P2	TWD 21		10H	-0.19	TEH	TEC	3		COLD	600UL
122	78	0.59	131	P2	TWD 23		VH1	-0.92	TEH	TEC	7		COLD	600UL
122	86	0.22	136	P3	TWD 8		DBH	+0.43	TEH	TEC	10		COLD	600UL
122	112	0.63	68	P2	TWD 24		10H	+0.76	TEH	TEC	12		COLD	600UL
122	116	0.31	30	P2	TWD 12		08H	-1.15	TEH	TEC	3		COLD	600UL
		0.45	152	P2	TWD 19		10H	+0.02	TEH	TEC	3		COLD	600UL
122	120	0.38	118	P2	TWD 14		08H	-0.73	TEH	TEC	3		COLD	600UL
		0.26	60	P2	TWD 10		08H	+0.57	TEH	TEC	3		COLD	600UL
		0.48	139	P2	TWD 19		VH1	-0.90	TEH	TEC	3		COLD	600UL
122	122	0.63	127	P2	TWD 24		10C	+0.87	TEH	TEC	1		COLD	600UL
123	45	0.71	114	P2	TWD 25		10C	+0.78	TEC	TEH	6		HOT	600UL
123	83	0.33	107	P3	TWD 13		DBH	-0.56	TEH	TEC	9		COLD	600UL
123	85	0.32	125	P3	TWD 13		DBH	-1.89	TEH	TEC	11		COLD	600UL
123	115	0.31	85	P2	TWD 12		09H	+0.40	TEH	TEC	3		COLD	600UL
123	117	0.66	137	P2	TWD 21		09H	-0.71	TEH	TEC	3		COLD	600UL
		0.19	37	P2	TWD 8		09H	+0.42	TEH	TEC	3		COLD	600UL
		0.27	36	P2	TWD 12		08H	+0.40	TEH	TEC	3		COLD	600UL
123	119	0.27	87	P2	TWD 11		09H	-0.17	TEH	TEC	4		COLD	600UL
		0.51	113	P2	TWD 19		09H	+0.50	TEH	TEC	4		COLD	600UL
124	58	0.36	108	P2	TWD 15		VH1	+0.70	TEH	TEC	24		COLD	600UL
124	78	0.40	151	P2	TWD 16		VH1	-0.94	TEH	TEC	8		COLD	600UL
124	98	0.28	118	P2	TWD 9		VH1	+0.96	TEH	TEC	15		COLD	600UL
124	114	0.19	127	P2	TWD 8		05H	+0.80	TEH	TEC	13		COLD	600UL
124	116	0.52	107	P2	TWD 19		08H	+0.91	TEH	TEC	4		COLD	600UL
		0.34	80	P2	TWD 14		09H	+0.23	TEH	TEC	4		COLD	600UL
		0.13	17	P2	TWD 5		10H	-0.97	TEH	TEC	4		COLD	600UL
125	45	0.19	143	P3	TWD 9		DBH	+0.31	TEC	TEH	6		HOT	600UL
125	57	0.67	121	P2	TWD 20		VH1	-0.90	TEH	TEC	25		COLD	600UL
		0.53	109	P2	TWD 17		VH1	+0.80	TEH	TEC	25		COLD	600UL
125	65	0.34	158	P2	TWD 12		VH1	+0.56	TEH	TEC	27		COLD	600UL
125	117	0.44	139	P2	TWD 17		08H	+0.94	TEH	TEC	4		COLD	600UL
126	62	0.35	71	P2	TWD 15		VH2	+0.70	TEH	TEC	26		COLD	600UL
		0.51	42	P2	TWD 20		VH1	-0.89	TEH	TEC	26		COLD	600UL
126	84	0.47	116	P2	TWD 20		VH1	+0.76	TEH	TEC	10		COLD	600UL
126	86	0.43	139	P2	TWD 18		VH1	-0.91	TEH	TEC	10		COLD	600UL
		0.37	69	P2	TWD 16		VH1	+0.82	TEH	TEC	10		COLD	600UL
126	108	0.47	72	P2	TWD 20		10H	+0.31	TEH	TEC	12		COLD	600UL
126	114	0.44	111	P2	TWD 19		08H	+0.90	TEH	TEC	12		COLD	600UL
126	132	0.53	82	P2	TWD 23		VH2	-0.93	TEC	TEH	7		HOT	600UL
127	51	0.42	31	P3	TWD 17		DBH	-1.59	TEH	TEC	23		COLD	600UL
127	61	0.49	96	P2	TWD 16		10H	+0.40	TEH	TEC	27		COLD	600UL

(de01) Post-U3C15 Inspection Results  
 MAI, MCI, MMI, MVI, SAI, SCI, SVI, TWD

QUERY: de01\_inspection\_results.qry

ROW	COL	VOLTS	DEG	CHN	IND	%TW	LOCATION	EXT	EXT	CAL #	LEG	PROBE
127	63	0.27	120	P2	TWD 10	VH1	-0.88	TEH	TEC	27	COLD	600UL
		0.39	107	P2	TWD 13	VH1	+0.88	TEH	TEC	27	COLD	600UL
127	65	0.41	152	P2	TWD 14	VH1	+0.69	TEH	TEC	27	COLD	600UL
127	67	0.35	123	P2	TWD 13	VH1	+0.10	TEH	TEC	29	COLD	600UL
127	79	0.73	91	P2	TWD 27	VH1	+0.79	TEH	TEC	7	COLD	600UL
127	85	0.73	110	P2	TWD 25	VH1	-0.69	TEH	TEC	11	COLD	600UL
127	101	0.29	127	P2	TWD 11	VH1	-0.68	TEH	TEC	14	COLD	600UL
127	111	0.45	56	P2	TWD 19	09H	-0.21	TEH	TEC	12	COLD	600UL
		0.50	96	P2	TWD 20	10H	+0.55	TEH	TEC	12	COLD	600UL
127	113	0.42	100	P2	TWD 18	08H	+0.94	TEH	TEC	12	COLD	600UL
		0.31	76	P2	TWD 14	09H	-0.80	TEH	TEC	12	COLD	600UL
		0.29	132	P2	TWD 13	09H	+0.35	TEH	TEC	12	COLD	600UL
127	115	0.30	56	P2	TWD 11	08H	-0.45	TEH	TEC	3	COLD	600UL
		0.39	124	P2	TWD 14	08H	+0.78	TEH	TEC	3	COLD	600UL
127	131	0.12	144	P3	TWD 5	DBH	+1.74	TEC	TEH	3	HOT	600UL
		0.35	87	P2	TWD 17	07H	+0.06	TEC	TEH	3	HOT	600UL
128	50	0.65	130	P2	TWD 24	VH2	-0.83	TEH	TEC	22	COLD	600UL
128	72	0.58	109	P2	TWD 22	VH1	-0.78	TEH	TEC	22	COLD	600UL
		0.72	68	P2	TWD 25	VH2	-0.83	TEH	TEC	22	COLD	600UL
128	76	0.47	140	P2	TWD 20	VH1	+0.67	TEH	TEC	7	COLD	600UL
128	110	0.21	160	P2	TWD 8	08H	-0.90	TEH	TEC	13	COLD	600UL
		0.21	138	P2	TWD 8	08H	+0.87	TEH	TEC	13	COLD	600UL
		0.33	137	P2	TWD 13	10H	+0.79	TEH	TEC	13	COLD	600UL
		0.27	142	P2	TWD 11	10H	-0.95	TEH	TEC	13	COLD	600UL
129	116	0.32	101	P2	TWD 13	VH1	+0.63	TEH	TEC	4	COLD	600UL
		0.28	57	P2	TWD 11	09C	+0.86	TEH	TEC	4	COLD	600UL
129	124	0.61	99	P2	TWD 21	VR2	+0.00	TEH	TEC	2	COLD	600UL
129	61	0.23	55	P2	TWD 8	VH1	-0.61	TEH	TEC	27	COLD	600UL
129	63	0.40	117	P2	TWD 14	10H	+0.50	TEH	TEC	27	COLD	600UL
		0.54	63	P2	TWD 17	VH1	+0.90	TEH	TEC	27	COLD	600UL
129	105	0.54	98	P2	TWD 20	VH1	+0.79	TEH	TEC	13	COLD	600UL
129	111	0.37	112	P2	TWD 14	09H	-0.83	TEH	TEC	13	COLD	600UL
		0.28	133	P2	TWD 11	09H	+0.53	TEH	TEC	13	COLD	600UL
130	50	0.51	148	P2	TWD 20	VH2	-0.81	TEH	TEC	22	COLD	600UL
130	54	0.21	20	P3	TWD 9	DBH	+1.78	TEH	TEC	24	COLD	600UL
130	62	0.71	107	P2	TWD 25	VH1	+0.91	TEH	TEC	26	COLD	600UL
130	66	0.51	90	P2	TWD 20	VH1	+0.76	TEH	TEC	26	COLD	600UL
130	68	0.48	95	P2	TWD 19	VH1	+0.89	TEH	TEC	28	COLD	600UL
		0.21	128	P3	TWD 8	DBH	-0.06	TEH	TEC	28	COLD	600UL
130	72	0.56	118	P2	TWD 22	VH1	+0.74	TEH	TEC	22	COLD	600UL
130	78	0.74	125	P2	TWD 27	VH1	+0.87	TEH	TEC	7	COLD	600UL
130	94	0.62	49	P2	TWD 22	VH1	+0.78	TEH	TEC	14	COLD	600UL
130	112	0.42	101	P2	TWD 16	VH2	-0.78	TEH	TEC	13	COLD	600UL
130	120	0.43	137	P2	TWD 17	VH2	-0.82	TEH	TEC	4	COLD	600UL
131	49	0.29	22	P3	TWD 13	DBH	+1.72	TEH	TEC	46	COLD	600UL



(de01) Post-U3C15 Inspection Results  
 MAI, MCI, MMI, MVI, SAI, SCI, SVI, TWD

QUERY: de01\_inspection\_results.qry

ROW	COL	VOLTS	DEG	CHN	IND	%TW	LOCATION	EXT	EXT	CAL #	LEG	PROBE
132	54	0.26	23	P3	TWD 9		DBH +1.64	TEH	TEC	45	COLD	600UL
132	60	0.65 0.74	37	P2	TWD 23		VH1 -0.85	TEH	TEC	45	COLD	600UL
			37	P2	TWD 25		VH2 -0.85	TEH	TEC	45	COLD	600UL
132	72	0.65 0.54	58	P2	TWD 23		10H +0.91	TEH	TEC	47	GOLD	600UL
			127	P2	TWD 20		VH1 +0.87	TEH	TEC	47	COLD	600UL
132	74	0.43	130	P2	TWD 17		VH2 -0.83	TEH	TEC	47	COLD	600UL
132	82	0.56	115	P2	TWD 21		VH1 -0.04	TEH	TEC	47	COLD	600UL
132	88	0.54	38	P2	TWD 20		VH1 +0.87	TEH	TEC	47	COLD	600UL
132	100	0.75 0.65	127	P2	TWD 25		VH1 -0.91	TEH	TEC	47	COLD	600UL
			126	P2	TWD 23		VH2 -0.87	TEH	TEC	47	COLD	600UL
132	110	0.37 0.30	79	P2	TWD 14		08H +0.93	TEH	TEC	50	COLD	600UL
			128	P2	TWD 11		07H +0.59	TEH	TEC	50	COLD	600UL
133	53	0.55 0.68	148	P3	TWD 21		DBH +1.68	TEH	TEC	46	COLD	600UL
			98	P2	TWD 24		07H +0.02	TEH	TEC	46	COLD	600UL
133	65	0.19	81	P3	TWD 9		DBH +1.55	TEH	TEC	46	COLD	600UL
133	93	0.19	40	P2	TWD 9		VH1 -0.94	TEH	TEC	48	COLD	600UL
133	95	0.35	131	P2	TWD 14		VH1 +0.78	TEH	TEC	47	COLD	600UL
133	101	0.40	133	P2	TWD 16		VH1 +0.73	TEH	TEC	48	COLD	600UL
133	103	0.46 0.16	99	P2	TWD 18		08H +0.87	TEH	TEC	48	COLD	600UL
			124	P2	TWD 7		VH1 -0.79	TEH	TEC	48	COLD	600UL
133	107	0.31 0.14 0.40	142	P2	TWD 13		09H +0.85	TEH	TEC	48	COLD	600UL
			156	P2	TWD 6		09H -0.83	TEH	TEC	48	COLD	600UL
			76	P2	TWD 16		VH2 +0.85	TEH	TEC	48	COLD	600UL
134	58	0.57	80	P2	TWD 21		VC3 +0.58	TEH	TEC	45	COLD	600UL
134	68	0.50 0.27	133	P2	TWD 19		10H -0.81	TEH	TEC	45	COLD	600UL
			40	P2	TWD 11		10H +0.85	TEH	TEC	45	COLD	600UL
134	74	0.70	115	P2	TWD 24		VH2 -0.90	TEH	TEC	48	COLD	600UL
134	80	0.65 0.33	136	P2	TWD 23		VH1 -0.79	TEH	TEC	48	COLD	600UL
			119	P2	TWD 14		VH1 +0.79	TEH	TEC	48	COLD	600UL
134	84	0.50	145	P2	TWD 19		VH1 -0.93	TEH	TEC	47	COLD	600UL
134	86	0.35	51	P2	TWD 14		10H +0.27	TEH	TEC	47	COLD	600UL
134	108	0.27	45	P2	TWD 12		10H +0.92	TEH	TEC	48	COLD	600UL
135	77	0.50	95	P2	TWD 19		VH1 +0.86	TEH	TEC	47	COLD	600UL
135	89	0.45	68	P2	TWD 18		VH3 -0.97	TEH	TEC	47	COLD	600UL
135	95	0.37	113	P2	TWD 15		VH1 -0.92	TEH	TEC	48	COLD	600UL
136	58	0.22	14	P3	TWD 10		DBH -1.63	TEH	TEC	46	COLD	600UL
136	74	0.47	92	P2	TWD 13		VH1 +0.88	TEH	TEC	47	COLD	600UL
136	90	0.52	75	P2	TWD 20		VH1 +0.82	TEH	TEC	47	COLD	600UL
136	94	0.67	125	P2	TWD 23		VH1 -0.94	TEH	TEC	48	COLD	600UL
137	59	0.34	22	P3	TWD 14		DBC +1.84	TEH	TEC	46	COLD	600UL
137	79	0.35	64	P2	TWD 15		09H -0.84	TEH	TEC	48	COLD	600UL
137	81	0.36	31	P2	TWD 15		08H +0.86	TEH	TEC	48	COLD	600UL
137	83	0.66	34	P2	TWD 23		09H +0.86	TEH	TEC	48	COLD	600UL

(de01) Post-U3C15 Inspection Results  
 MAI, MCI, MMI, MVI, SAI, SCI, SVI, TWD

QUERY: de01\_inspection\_results.qry

ROW	COL	VOLTS	DEG	CHN	IND	%TW	LOCATION	EXT	EXT	CAL #	LEG	PROBE	
137	91	0.60	101	P2	TWD	22	09H	+0.81	TEH	TEC	48	COLD	600UL
		0.45	142	P2	TWD	18	VH1	+0.88	TEH	TEC	48	COLD	600UL
137	115	0.39	96	P2	TWD	18	VH2	-0.84	TEH	TEC	49	COLD	600UL
138	76	0.51	138	P2	TWD	19	10H	+0.85	TEH	TEC	47	COLD	600UL
138	104	0.54	135	P2	TWD	20	VH1	-0.81	TEH	TEC	48	COLD	600UL
		0.22	90	P2	TWD	10	VH1	-0.21	TEH	TEC	48	COLD	600UL
139	85	0.33	97	P2	TWD	14	VH3	+0.88	TEH	TEC	47	COLD	600UL
139	89	0.52	111	P2	TWD	20	09H	+0.91	TEH	TEC	47	COLD	600UL
		0.25	155	P2	TWD	10	09H	-0.99	TEH	TEC	47	COLD	600UL
139	95	0.24	85	P2	TWD	10	VH1	-0.94	TEH	TEC	48	COLD	600UL
139	99	0.28	83	P2	TWD	12	VH2	-0.95	TEH	TEC	47	COLD	600UL
140	64	0.70	67	P3	TWD	25	DBH	-1.59	TEH	TEC	46	COLD	600UL
140	112	0.37	125	P2	TWD	17	04H	+0.77	TEH	TEC	49	COLD	600UL
		0.48	45	P3	TWD	18	DBC	-1.60	TEH	TEC	49	COLD	600UL
		0.36	123	P3	TWD	14	DBC	+1.64	TEH	TEC	49	COLD	600UL
141	67	0.35	130	P2	TWD	14	VH1	-0.78	TEH	TEC	46	COLD	600UL
		0.22	56	P3	TWD	9	DBC	-1.61	TEH	TEC	46	COLD	600UL
141	87	0.40	66	P2	TWD	16	VH2	+0.89	TEH	TEC	48	COLD	600UL
141	97	0.32	64	P3	TWD	14	DBC	-1.57	TEH	TEC	48	COLD	600UL
141	99	0.35	109	P3	TWD	15	DBH	+2.07	TEH	TEC	48	COLD	600UL
		0.30	105	P2	TWD	13	VH1	+0.96	TEH	TEC	48	COLD	600UL
142	82	0.68	29	P3	TWD	24	DBC	+1.81	TEH	TEC	48	COLD	600UL
143	95	0.25	43	P3	TWD	11	DBH	-1.59	TEH	TEC	48	COLD	600UL
144	70	0.60	92	P2	TWD	22	VC1	+0.54	TEH	TEC	46	COLD	600UL
144	76	0.20	90	P3	TWD	9	DBH	-1.80	TEH	TEC	48	COLD	600UL
144	78	0.46	86	P3	TWD	18	DBH	-1.61	TEH	TEC	48	COLD	600UL
144	80	0.41	168	P3	TWD	15	DBH	+1.97	TEH	TEC	47	COLD	600UL
144	84	0.54	51	P2	TWD	20	VH3	+0.83	TEH	TEC	48	COLD	600UL
144	94	0.34	126	P3	TWD	15	DBH	+1.82	TEH	TEC	48	COLD	600UL
144	102	0.33	126	P2	TWD	16	09H	-1.01	TEH	TEC	49	COLD	600UL
		0.34	168	P3	TWD	13	DBC	+2.04	TEH	TEC	49	COLD	600UL
		0.37	119	P3	TWD	14	DBC	-1.90	TEH	TEC	49	COLD	600UL
145	73	0.34	93	P3	TWD	14	DBH	+1.86	TEH	TEC	48	COLD	600UL
145	79	0.22	108	P3	TWD	10	DBH	-1.87	TEH	TEC	48	COLD	600UL
145	97	0.27	110	P3	TWD	12	DBC	-1.94	TEH	TEC	48	COLD	600UL
146	90	0.35	124	P2	TWD	14	VH3	-0.83	TEH	TEC	48	COLD	600UL
		0.50	66	P3	TWD	19	DBC	+1.79	TEH	TEC	48	COLD	600UL
146	92	0.92	46	P3	TWD	29	DBH	+2.15	TEH	TEC	48	COLD	600UL

Total Tubes : 513  
 Total Records: 692