

THE SLIDES IN THIS ENCLOSURE 2 MAY BE MADE PUBLIC.

ENCLOSURE 2

REDACTED PRESENTATION SLIDES

---

## **CASTOR<sup>®</sup> geo69**

### **Organization and content of the upcoming 10 CFR Part 71 application for package approval**

GNS Gesellschaft für Nuklear-Service mbH

---

This document contains business and trade secrets of GNS.  
v2

---

## **GNS Corporate Information**

## Competence for Nuclear Services

A medium-sized company founded in 1974, based in Essen/Germany.



- Competence Centre of the German utilities for the management of spent fuel and all nuclear wastes (HLW/ILW/LLW) from the operation and the dismantling of the German power plants
- **Worldwide operations :**
  - as one of the leading manufacturers of casks for ILW (MOSAİK®) and spent fuel/HLW (CASTOR®, CONSTOR®)
  - for processing of every kind of radioactive waste, decommissioning and related engineering services



This document may not be cited, reproduced in whole or in part, or made available to third parties without the prior written consent of GNS Gesellschaft für Nuklear-Service mbH, Essen. All rights reserved by GNS. This document contains business and trade secrets of GNS.

2019-02-21 / Pre-Application Meeting NRC / 3

## Organisation



**Dr. Hannes Wimmer**  
*Chairman of the  
Management Board*

**CEO**

Strategy, Sales,  
Communications

Waste  
Management

Waste Management  
Projects  
LLW / ILW / HLW

**WTI**



**Dr. Jens Schröder**  
*Member of the  
Management Board*

**CTO**

Casks for HLW and  
Spent Fuel

Casks for  
LLW/ILW

Cask Loading  
and Service

Equipment and  
Systems Engineering



**Georg Büth**  
*Member of the  
Management Board*

**CFO**

Controlling

Finance, Taxes,  
Procurement

IT Systems,  
General  
Administration

Human Resources,  
Legal



This document may not be cited, reproduced in whole or in part, or made available to third parties without the prior written consent of GNS Gesellschaft für Nuklear-Service mbH, Essen. All rights reserved by GNS. This document contains business and trade secrets of GNS.

2019-02-21 / Pre-Application Meeting NRC / 4

## The Company

- **Headquarters Essen**
  - Corporate Functions
  - Project Planning and Controlling
  - Development of Casks and Equipment



Turn over > 250 Mio. Euro  
Employees about 450

### Shareholders



### Subsidiary



- **Jülich**
  - Conditioning and packaging of solid LLW



- **Mülheim**
  - Cask assembly (SF, HLW, ILW)
  - Training and Test Facility



This document may not be cited, reproduced in whole or in part, or made available to third parties without the prior written consent of GNS Gesellschaft für Nuklear-Service mbH, Essen. All rights reserved by GNS. This document contains business and trade secrets of GNS.

2019-02-21 / Pre-Application Meeting NRC / 5

## Competence Areas of GNS

- **Management of nuclear waste** from operations and dismantling of nuclear power plants (ILW/LLW)
- **Management of spent fuel** as well as ILW and HLW from the reprocessing of German spent fuel abroad
- **Casks for transport and storage** of spent fuel and nuclear waste (HLW/ILW)
- Consulting, engineering and equipment
- Preparations for final disposal
- **Operation of Storage Facilities** (until mid 2017 part of GNS, now part of government owned BGZ)



This document may not be cited, reproduced in whole or in part, or made available to third parties without the prior written consent of GNS Gesellschaft für Nuklear-Service mbH, Essen. All rights reserved by GNS. This document contains business and trade secrets of GNS.

2019-02-21 / Pre-Application Meeting NRC / 6

## Further international Development

---

- **Germany is phasing out of Nuclear Energy**
  - Last spent fuel cask to be delivered for German market in 2025
  - Last casks for waste of reprocessing to be delivered ca. 2035
- **Focus on international customer**
  - Almost 100 CASTOR cask for dry storage of spent fuel contracted for customers outside Germany in the past three years
- **Target Markets**
  - *Europe:* Belgium, Switzerland, Spain, Czech Republic
  - *Asia:* Japan, Korea, Taiwan, (China)
  - *Rest of the World:* South Africa, (USA)



This document may not be cited, reproduced in whole or in part, or made available to third parties without the prior written consent of GNS Gesellschaft für Nuklear-Service mbH, Essen. All rights reserved by GNS. This document contains business and trade secrets of GNS.

2019-02-21 / Pre-Application Meeting NRC / 7



## CASTOR® Spent Fuel Management

# CASTOR® Casks by GNS



First CASTOR® cask  
Still in operation/storage



Transport of a  
CASTOR® cask



CASTOR® casks at  
indoor storage facility

- Since the very first dry storage cask loading in 1983 the design principle of CASTOR® casks remains unchanged
  - CASTOR® casks by GNS are Dual-Purpose Casks
    - No overpack required for transportation and storage
    - Shielding is performed by the cask itself
    - "Load & Go" / "Store & Go"
  - CASTOR® casks consist of a monolithic DCI cask body and metal sealings in all lids of the containment
    - No welding seams
    - Suitable for long-term storage
    - Major cost savings compared to forged steel
  - CASTOR® casks features continuous pressure monitoring
    - 24/7 monitoring for any possible leakage



This document may not be cited, reproduced in whole or in part, or made available to third parties without the prior written consent of GNS Gesellschaft für Nuklear-Service mbH, Essen. All rights reserved by GNS. This document contains business and trade secrets of GNS.

2019-02-21 / Pre-Application Meeting NRC / 9

## The CASTOR® Concept



Dual-purpose casks of GNS fulfil all protection goals during transport and dry interim storage:

- **Safe enclosure of the radioactive contents**
  - Monolithic cask body (ductile cast iron)
  - Double barrier lid system (forged steel)
  - Lid system permanently monitored for leak-tightness during interim storage
- **Shielding of radiation**
  - Thick-walled cask body (about 350 to 400 mm)
  - Polyethylene rods inside the cask wall and PE plates at both ends
- **Dissipation of decay heat**
  - Radial cooling fins machined into the cask wall enlarge the surface of the cask
- **Guarantee of subcriticality**
  - The design of the cask and its components (lids, basket, impact limiters) guarantee subcriticality under standard and accident conditions.



This document may not be cited, reproduced in whole or in part, or made available to third parties without the prior written consent of GNS Gesellschaft für Nuklear-Service mbH, Essen. All rights reserved by GNS. This document contains business and trade secrets of GNS.

2019-02-21 / Pre-Application Meeting NRC / 10

## CASTOR® Variety

- Customized to a variety of reactor types including: PWR, BWR, VVER 440, VVER 1000, MTR, etc.
- Type B(U)F package design approval certificates (incl. validations) including:
  - Germany,
  - Belgium,
  - Czech Republic,
  - Netherlands,
  - Switzerland,
  - France,
  - UK,
  - USA.



- Storage licenses in many countries worldwide



This document may not be cited, reproduced in whole or in part, or made available to third parties without the prior written consent of GNS Gesellschaft für Nuklear-Service mbH, Essen. All rights reserved by GNS. This document contains business and trade secrets of GNS.

2019-02-21 / Pre-Application Meeting NRC / 11

## GNS Casks Worldwide

**GNS has already developed and manufactured almost 1700 casks for High Level Waste and Spent Fuel.**

### Casks loaded and in interim storage:

▪ Germany	1266
▪ Lithuania (Ignalina)	203
▪ Czech Republic (Dukovany, Temelin)	124
▪ USA (e.g. Surry)	35
▪ Switzerland	14
▪ Bulgaria (Kozloduy)	13
▪ Belgium	7
▪ South Africa	4

### Additional casks delivered to:

- Finland, France, the Netherlands, Russia, Korea



As of December 2018



This document may not be cited, reproduced in whole or in part, or made available to third parties without the prior written consent of GNS Gesellschaft für Nuklear-Service mbH, Essen. All rights reserved by GNS. This document contains business and trade secrets of GNS.

2019-02-21 / Pre-Application Meeting NRC / 12

## Manufacturing of the CASTOR® Cask Body

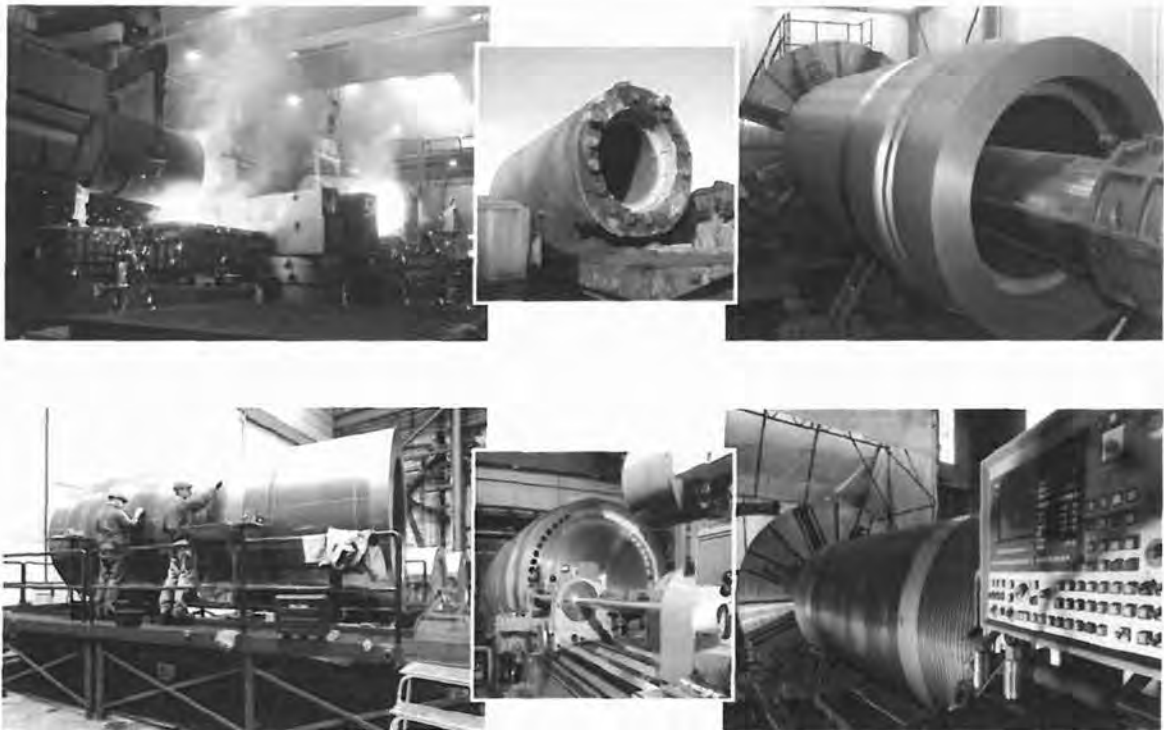

This document may not be cited, reproduced in whole or in part, or made available to third parties without the prior written consent of GNS Gesellschaft für Nuklear-Service mbH, Essen. All rights reserved by GNS. This document contains business and trade secrets of GNS.

2019-02-21 / Pre-Application Meeting NRC / 13

## Assembly of CASTOR® Cask



This document may not be cited, reproduced in whole or in part, or made available to third parties without the prior written consent of GNS Gesellschaft für Nuklear-Service mbH, Essen. All rights reserved by GNS. This document contains business and trade secrets of GNS.

2019-02-21 / Pre-Application Meeting NRC / 14



# GNS Cask Assembly at Mülheim



This document may not be cited, reproduced in whole or in part, or made available to third parties without the prior written consent of GNS Gesellschaft für Nuklear-Service mbH, Essen. All rights reserved by GNS. This document contains business and trade secrets of GNS.

2019-02-21 / Pre-Application Meeting NRC / 15



## CASTOR<sup>®</sup> geo and CLU



## „German Fuel“ vs. Rest of the World

- German PWR fuel features larger diameters compared to international established PWR fuel

◌ KWU:  $\varnothing = 230 \text{ mm}$

- Areva :  $\varnothing = 214 \text{ mm}$
  - Westinghouse:  $\varnothing = 197 / 214 \text{ mm}$
  - CE-Type:  $\varnothing = 207 \text{ mm}$
- **Baskets optimized for fuel with largest diameters result in smaller amounts of FA per cask**

- German NPPs run larger burn-ups compared to most other countries in the world
- German NPPs have a demand for shorter cooling times compared to most other countries

- **Baskets optimized for rather hot fuel result in smaller amounts of FA per cask**

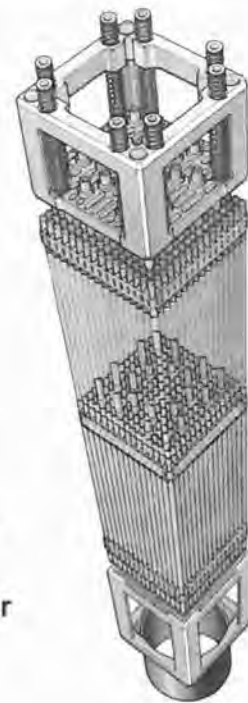

This document may not be cited, reproduced in whole or in part, or made available to third parties without the prior written consent of GNS Gesellschaft für Nuklear-Service mbH, Essen. All rights reserved by GNS. This document contains business and trade secrets of GNS.

2019-02-21 / Pre-Application Meeting NRC / 17

## The CASTOR® geo Family

- Customized basket design
  - Optimized for high fuel capacity
- Established design principles incl. DCI cask body
  - Major cost advantages compared to forged steel cask bodies
- Based on standardized modules and components
  - Saves time and funds for licensing
- Standardized handling and dispatch of the casks
  - Savings in equipment due to standardizations

Storage Configuration



Basket for 32 PWR FA



This document may not be cited, reproduced in whole or in part, or made available to third parties without the prior written consent of GNS Gesellschaft für Nuklear-Service mbH, Essen. All rights reserved by GNS. This document contains business and trade secrets of GNS.

2019-02-21 / Pre-Application Meeting NRC / 18

## First Customers for New Casks

- **Belgium:**
  - 30 CASTOR® geo contracted in 2016
  - Delivery from 2021 onwards
    - Units 1-3 of Tihange NPP
    - Units 3-4 of Doel NPP
- **Switzerland:**
  - 51 CASTOR® geo contracted in 2016
  - Delivery from 2024 onwards
    - Gösgen NPP



This document may not be cited, reproduced in whole or in part, or made available to third parties without the prior written consent of GNS Gesellschaft für Nuklear-Service mbH, Essen. All rights reserved by GNS. This document contains business and trade secrets of GNS.

2019-02-21 / Pre-Application Meeting NRC / 19

## The CASTOR® CLU System

### Next Challenge for GNS:

Complete defueling of dated US-type NPPs prior to decommissioning



### Boundaries

- Crane Capacity often around 100 US-tons (90,7 Mg) with no option to upgrade
- Reasonable spent fuel specifications in terms of burn-up, cooling times etc.
- Demand for accelerated defueling as many of the old plants retire with immediate decommissioning.



This document may not be cited, reproduced in whole or in part, or made available to third parties without the prior written consent of GNS Gesellschaft für Nuklear-Service mbH, Essen. All rights reserved by GNS. This document contains business and trade secrets of GNS.

2019-02-21 / Pre-Application Meeting NRC / 20

# The CASTOR® CLU System



## CLU → Cask Loading Unit

- Canister based system for internal transfer increases FA capacity with given pool crane
- Dual Purpose Cask with bolted double lid system for storage and public transport
- Smooth licensing expected since majority of the existing reviewed safety cases of the CASTOR® cask might be re-used for the CLU system



This document may not be cited, reproduced in whole or in part, or made available to third parties without the prior written consent of GNS Gesellschaft für Nuklear-Service mbH, Essen. All rights reserved by GNS. This document contains business and trade secrets of GNS.

2019-02-21 / Pre-Application Meeting NRC / 21

# CASTOR® CLU System – Glossary

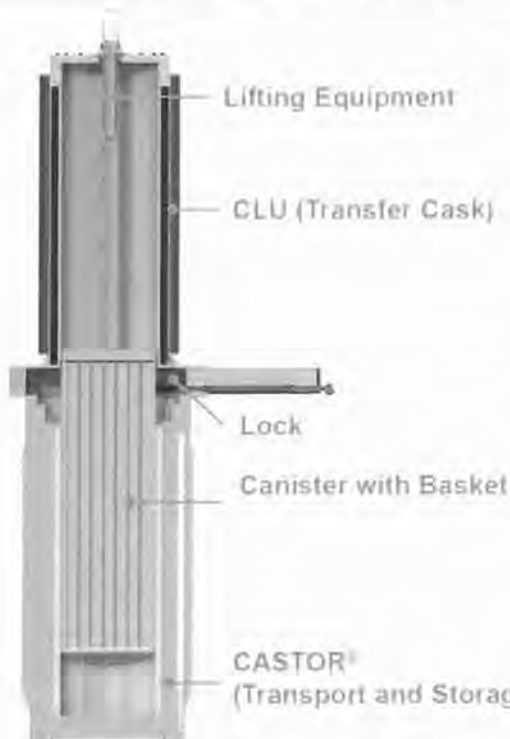

## CLU → Cask Loading Unit

- Canister is loaded under water and dispatched next to the pool while placed in the CLU
- Canister is closed by a dedicated lid with a bayonet locking system
- Canister handling inside plant within the CLU
- Bottom of CLU removable into the lock in order to lower the canister from the CLU into the CASTOR® cask
- Transports and storage inside the established CASTOR® casks with standard lid / sealing system



This document may not be cited, reproduced in whole or in part, or made available to third parties without the prior written consent of GNS Gesellschaft für Nuklear-Service mbH, Essen. All rights reserved by GNS. This document contains business and trade secrets of GNS.

2019-02-21 / Pre-Application Meeting NRC / 22

## Quality Assurance



This document contains business and trade secrets of GNS v2

## Quality Assurance



- GNS Integrated Management System is based on ISO 9001:2015
- Meets the requirements for quality management (QM) in accordance with IAEA SSR-6 and with the German regulation BAM-GGR 011 "Quality Assurance Measures of Packagings for Competent Authority Approved Package Designs for the Transport of Radioactive Material"
- Scope includes the development, manufacturing and operation of packagings of approved packages for the transport of radioactive material.

## Quality Assurance



- Quality Assurance Program (QAP) acc. to ASME Section III Division 3 is implemented separately to the Integrated Management System (IMS) of GNS
- The Quality Assurance Manual (ASME-QAM) is in compliance with NQA-1 Part I
- QAP implemented and established at GNS in year 2018
- ASME Survey scheduled for April 8-11, 2019
- GNS intends to become N3 stamp holder



This document may not be cited, reproduced in whole or in part, or made available to third parties without the prior written consent of GNS Gesellschaft für Nuklear-Service mbH, Essen. All rights reserved by GNS. This document contains business and trade secrets of GNS.

2019-02-21 / Pre-Application Meeting NRC / 25

## Quality Assurance



- The 10 CFR Part 71 Subpart H requirements are implemented in a Quality Assurance Manual (QAM II) which refers to the ASME-QAM
- Description of the Quality Assurance Program will be part of the Subpart D application
- Procedure of acceptance of QA Program by NRC to be defined
- Quality Project Manual (QPM) serve project-specifically as interface to regulatory, codes & standards, and customer requirements



This document may not be cited, reproduced in whole or in part, or made available to third parties without the prior written consent of GNS Gesellschaft für Nuklear-Service mbH, Essen. All rights reserved by GNS. This document contains business and trade secrets of GNS.

2019-02-21 / Pre-Application Meeting NRC / 26

## Project Introduction



This document contains business and trade secrets of GNS  
v2

## Project Objectives



- Package approval of CASTOR® geo69 as Type B(U)F package according to 10 CFR Part 71
- Challenges
  - Design of a class TC transport containment according to ASME BPVC Edition 2017, Section III, Division 3, part WB
  - Conversion of design and manufacturing specifications to US-compliant standards
  - Adoption of US-compliant standards of safety-proofs and licensing applications

# Licensing Procedure



- Applicant:
  - GNS Gesellschaft für Nuklear-Service mbH,  
Frohnhauser Straße 67, 45127 Essen, Germany
- Contents of application:
  - Package description in accordance with §71.33
  - Package evaluation in accordance with §71.35
  - Quality assurance description in accordance with §71.37
- Time schedule:
  - Submission of SAR and QA description  
in December 2019
- URENCO USA Inc. will support GNS



This document may not be cited, reproduced in whole or in part, or made available to third parties without the prior written consent of GNS Gesellschaft für Nuklear-Service mbH, Essen. All rights reserved by GNS. This document contains business and trade secrets of GNS.

2019-02-21 / Pre-Application Meeting NRC / 29

## Targeting Market

Proprietary Information withheld per 10CFR2.390



This document may not be cited, reproduced in whole or in part, or made available to third parties without the prior written consent of GNS Gesellschaft für Nuklear-Service mbH, Essen. All rights reserved by GNS. This document contains business and trade secrets of GNS.

2019-02-21 / Pre-Application Meeting NRC / 30



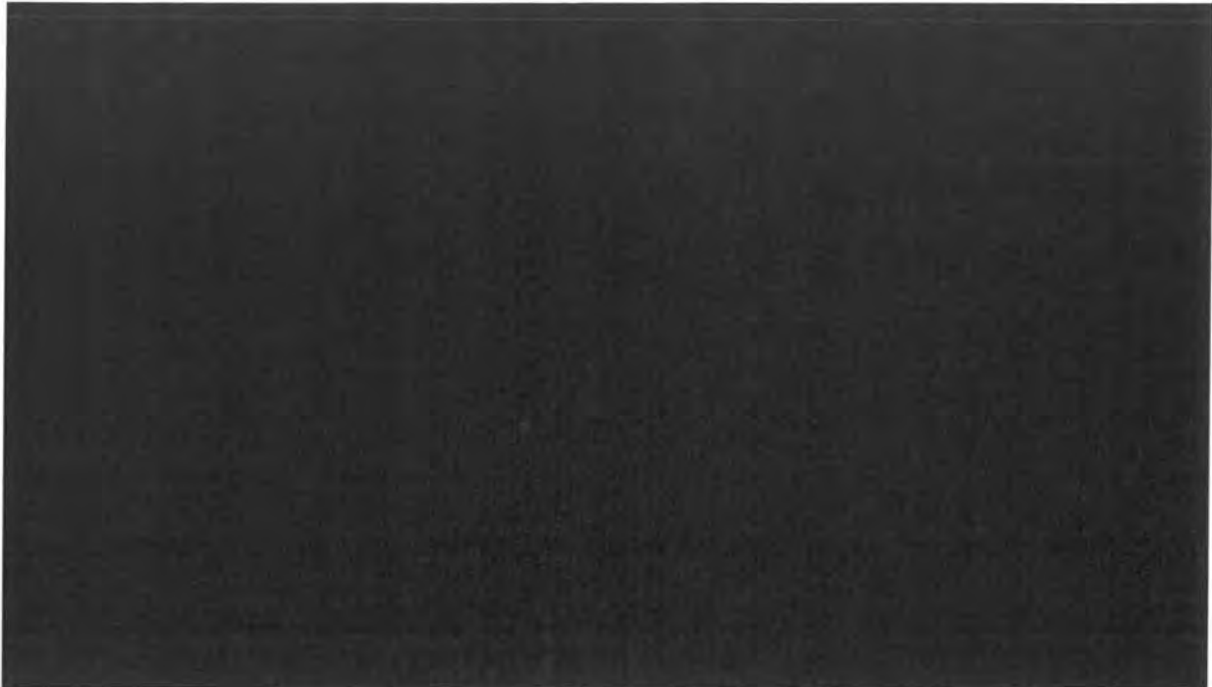

This document may not be cited, reproduced in whole or in part, or made available to third parties without the prior written consent of GNS Gesellschaft für Nuklear-Service mbH, Essen. All rights reserved by GNS. This document contains business and trade secrets of GNS.

2019-02-21 / Pre-Application Meeting NRC / 31



## Technical Description of the Cask Concept



## Package Overview – Main Components

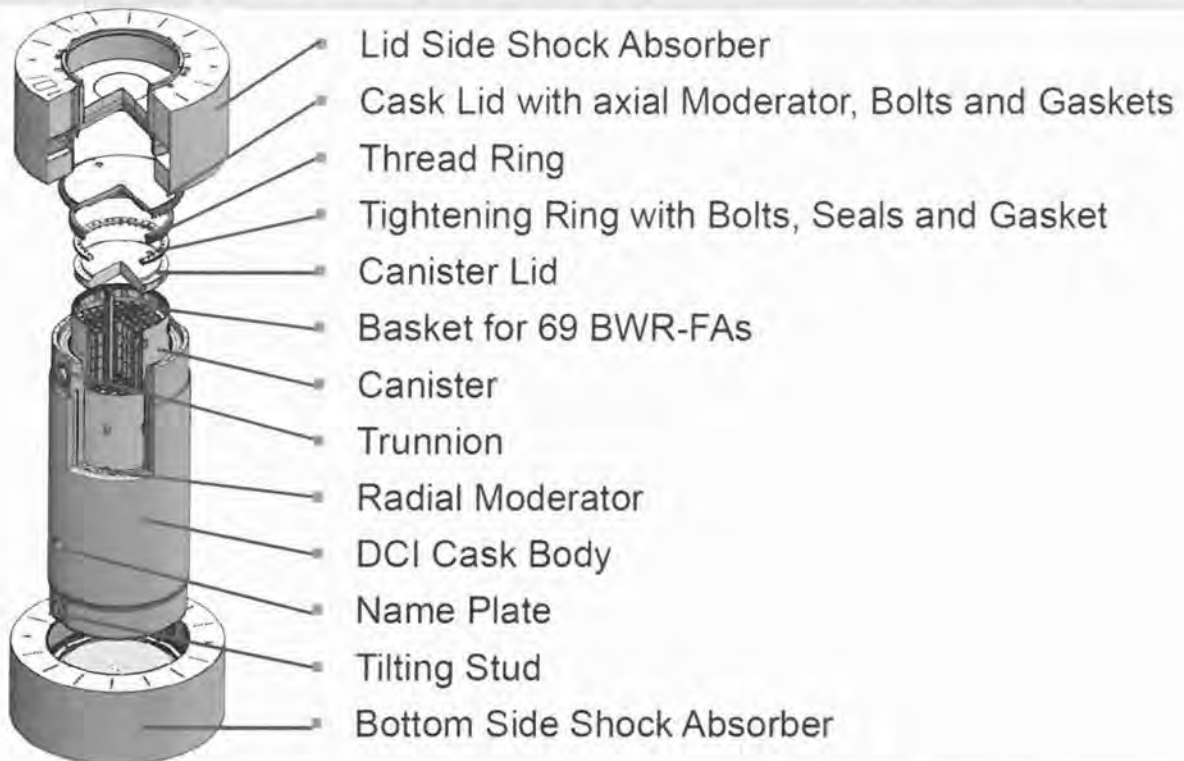

GNS

This document may not be cited, reproduced in whole or in part, or made available to third parties without the prior written consent of GNS Gesellschaft für Nuklear-Service mbH, Essen. All rights reserved by GNS. This document contains business and trade secrets of GNS.

2019-02-21 / Pre-Application Meeting NRC / 33

## Applied Radioactive Content

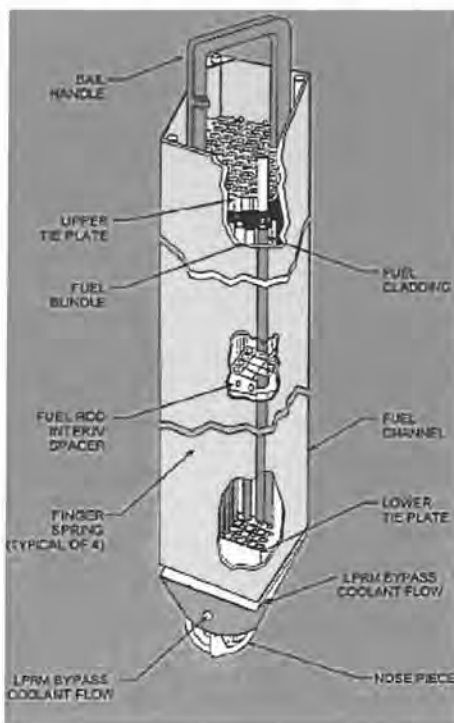

- BWR Fuel Assemblies with or w/o Fuel Channel
- Dimensions (nominal)
  - Cross Section  $\leq \square 140 \text{ mm}$
  - Overall length  $\leq 4450 \text{ mm}$
  - Total weight  $\leq 322 \text{ kg}$
- Data of Fresh Fuel
  - Fuel Type UO<sub>2</sub>
  - Weight HM  $\leq 185 \text{ kg}$
  - Length active zone  $\leq 3810 \text{ mm}$
  - Enrichment  $3.0 \dots \leq 4,6 \text{ wt-\%}$
- Irradiation
  - Burnup  $20 \dots \leq 60 \text{ GWd/MgHM}$
  - Cooling Time  $\geq 10 \text{ years} \dots 40$



GNS

This document may not be cited, reproduced in whole or in part, or made available to third parties without the prior written consent of GNS Gesellschaft für Nuklear-Service mbH, Essen. All rights reserved by GNS. This document contains business and trade secrets of GNS.

2019-02-21 / Pre-Application Meeting NRC / 34

## Description of cask concept - Basket

Proprietary Information withheld per 10CFR2.390

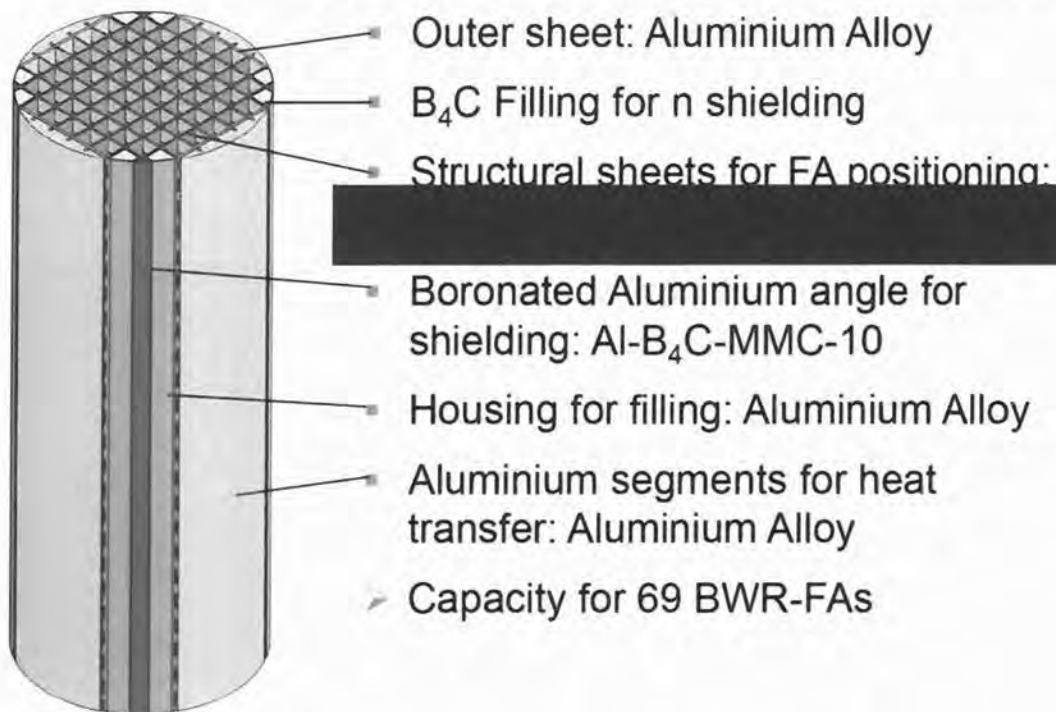

This document may not be cited, reproduced in whole or in part, or made available to third parties without the prior written consent of GNS Gesellschaft für Nuklear-Service mbH, Essen. All rights reserved by GNS. This document contains business and trade secrets of GNS.

2019-02-21 / Pre-Application Meeting NRC / 35

## Description of cask concept - Canister

Proprietary Information withheld per 10CFR2.390

- - - - - : Supplement Containment boundary for Burnup > 45 GWD/MgHM
- Welded stainless Steel Liner and Bottom
- Bolted lid, sealed by metal gaskets
- Geometry (Lo/li, Do/di):
- → Able for Handling of loaded Canister



This document may not be cited, reproduced in whole or in part, or made available to third parties without the prior written consent of GNS Gesellschaft für Nuklear-Service mbH, Essen. All rights reserved by GNS. This document contains business and trade secrets of GNS.

2019-02-21 / Pre-Application Meeting NRC / 36

## Description of cask concept - Cask Containment

Proprietary Information withheld per 10CFR2.390

- - - - - : Containment boundary for Burnup < 45 GWD/MgHM
- DCI CASTOR® cask → Excellent Experience in Germany
  - Monolithic cast Cask Body [REDACTED]
  - Accordance with ASME Sec. II (DCI SA-874M) → Qualification
  - Geometry ( $L_o/l_i$ ,  $D_o/d_i$ ): [REDACTED]
- Bolted Cask Lid with double metal Gasket → Excellent Experience, experimental investigation
- [REDACTED]
- Integrated Moderator Rods in the Cask Wall → Qualification necessary?
- Handling via Lid Side Trunnions
- Tilting via Bottom Side Tilting Studs



This document may not be cited, reproduced in whole or in part, or made available to third parties without the prior written consent of GNS Gesellschaft für Nuklear-Service mbH, Essen. All rights reserved by GNS. This document contains business and trade secrets of GNS.

2019-02-21 / Pre-Application Meeting NRC / 37

## Description of cask concept - Transport Configuration

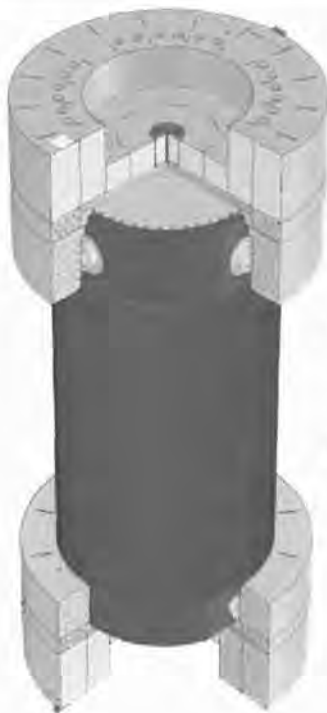

- Lid and Bottom Side Shock Absorbers → Sufficient for Load protection for ACT, worst case 9 m Drop orientation
- Shock absorbing Material (PU) → NRC acceptance for other designs
- Transport Frame → Interface with Transport Vehicle
- No load application on Trunnions during Transport → Weight load directly on Cask body



This document may not be cited, reproduced in whole or in part, or made available to third parties without the prior written consent of GNS Gesellschaft für Nuklear-Service mbH, Essen. All rights reserved by GNS. This document contains business and trade secrets of GNS.

2019-02-21 / Pre-Application Meeting NRC / 38

## Safety related Function of Main Components

Safety Related Function	Containment	Subcriticality	Shielding	Heat Transfer	Cask Handling
Basket		x	x	x	x
Canister	x (1)		x	x	
Canister Lid	x (1)		x		x
Tightening Ring	x (1)				
DCI Cask Body	x		x	x	
Moderator rods inside Cask Body			x		
Cask Lid	x		x		
Cask Lid Bolting	x				
Moderator Plate			x		
Retention Ring					
Lidside Trunnion					x

x - Main Function

(1) - Supplement Containment, if Burnup > 45 Gwd/t



This document may not be cited, reproduced in whole or in part, or made available to third parties without the prior written consent of GNS Gesellschaft für Nuklear-Service mbH, Essen. All rights reserved by GNS. This document contains business and trade secrets of GNS.

2019-02-21 / Pre-Application Meeting NRC / 39

## Materials of Main Components

Component	Raw Product	Material Group	Construction Code
Basket	rolled Plate	boronated Aluminium	ASME Section II and Section III, Div.3 Subsection WD (1)
Basket	Extrusions	Aluminium	ASME Section II and Section III, Div.3 Subsection WD
Canister	rolled Plate	Stainless Steel	ASME Section II and Section III, Div.3 Subsection WB
Canister Lid	Forging	Stainless Steel	ASME Section II and Section III, Div.3 Subsection WB ANSI N14.6
Tightening Ring	Forging / Plate	Stainless Steel	ASME Section II and Section III, Div.3 Subsection WB
Metallic Gasket - Typ Helicoflex HN200	Commercial Product	Silver/Stainless Steel	(2) - ANSI N14.5
DCI Cask Body	Casting	Ductile Cast Iron	ASME Section II and Section III, Div.3 Subsection WB
Moderator rods inside Cask Body	Plate	Polyethylene	(2)
Cask Lid	Forging	Stainless Steel	ASME Section II and Section III, Div.3 Subsection WB
Cask Lid Bolting	Forging	Stainless Steel	ASME Section II and Section III, Div.3 Subsection WB
Metallic Gasket - Typ Helicoflex HN200	Commercial Product	Silver/Stainless Steel	(2) - ANSI N14.5
Moderator Plate	Plate	Polyethylene	(2)
Retention Ring	Forging / Plate	Stainless Steel	ASME Section II and Section III, Div.3 Subsection WB
Lidside Trunnion	Forging	Stainless Steel	ANSI N14.6
Impact limiter	Foam	Polyurethan	(2)

(1) - Alternative Material not within the Code

(2) - No Code requirement



This document may not be cited, reproduced in whole or in part, or made available to third parties without the prior written consent of GNS Gesellschaft für Nuklear-Service mbH, Essen. All rights reserved by GNS. This document contains business and trade secrets of GNS.

2019-02-21 / Pre-Application Meeting NRC / 40

## Safety Proofs



This document contains business and trade secrets of GNS.  
v2

### Safety Requirements (10 CFR 71 et al.)

- Criticality safety → Verification of max.  $k_{\text{eff}}$
- Activity retention → Verification of max. leak rate
- Radiation shielding → Verification of max. dose rate
- Structural integrity → Verification of stress tests (NCT, ACT)
- Passive heat dissipation → Verification of thermal loads
  - 10 CFR 71, e.g. §§ 71.55, 71.59, 71.71/.73, 71.107
  - NRC Reg. Guide 7.4 → Leakage test requirements
  - NRC Reg. Guide 7.6 → Mechanical load criteria
  - NRC Reg. Guide 7.8 → Load combinations
  - NRC Reg. Guide 7.9, Ch. 6
  - Further cited standards, e.g. ASME Sec. III; ANSI N14.5, N14.6

## Design Methodology

*The effects on a package ... , must be evaluated by subjecting a specimen or scale model to a specific test, or by another method of demonstration acceptable to the Commission, as appropriate for the particular feature being considered.*

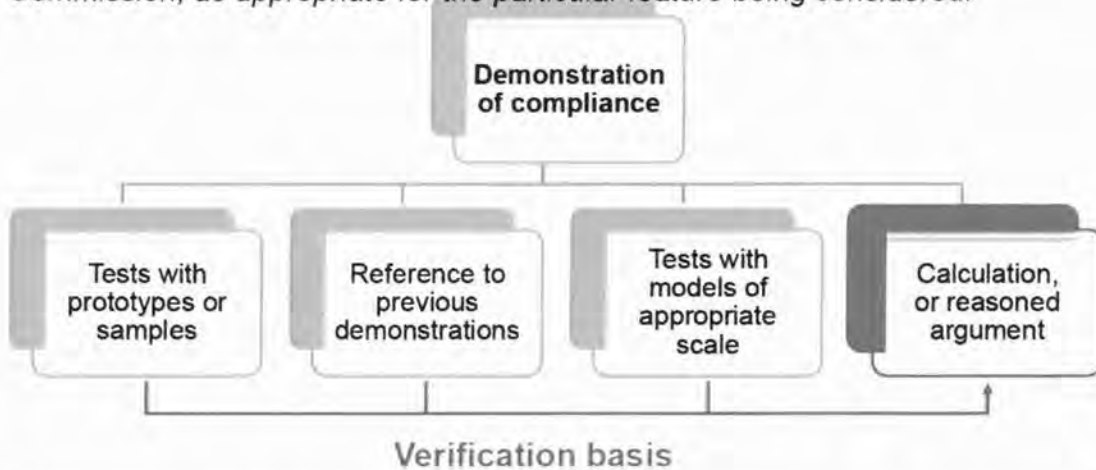

**The safety analyses of the CASTOR® geo69 will be carried out by means of calculations which are verified by various tests with samples and scaled models.**



This document may not be cited, reproduced in whole or in part, or made available to third parties without the prior written consent of GNS Gesellschaft für Nuklear-Service mbH, Essen. All rights reserved by GNS. This document contains business and trade secrets of GNS.

2019-02-21 / Pre-Application Meeting NRC / 43

## Approach to Demonstrate Safety

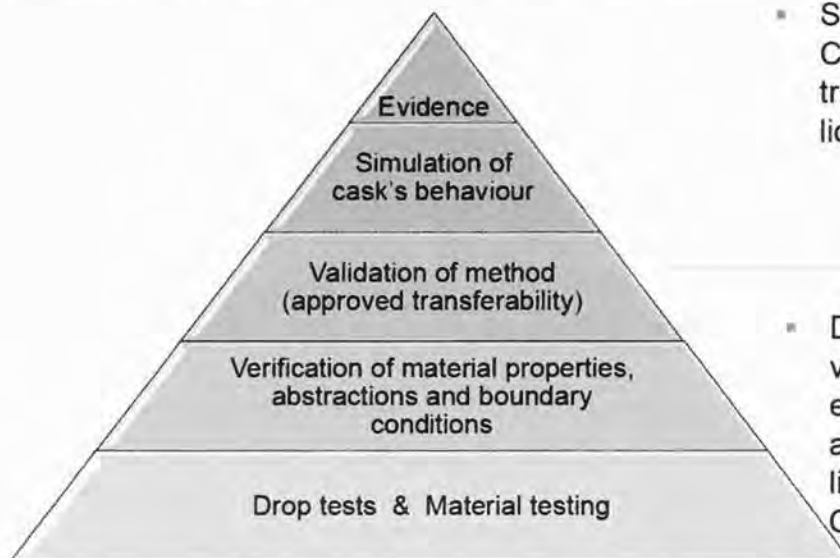

- Safety Case of CASTOR® geo69 for transport and storage licensing applications

- Design methodology verified by numerous experiments and approved within several licensing processes of CASTOR® casks

**The applied cask type is based on the established CASTOR® concept, which relies on the long-term tested and continuously licensed, fabricated and applied cask design.**



This document may not be cited, reproduced in whole or in part, or made available to third parties without the prior written consent of GNS Gesellschaft für Nuklear-Service mbH, Essen. All rights reserved by GNS. This document contains business and trade secrets of GNS.

2019-02-21 / Pre-Application Meeting NRC / 44

## Drop Tests with a Half Scale Cask

- Instrumented drop tests sequences (2005 – 2006) according to Type B(U)F accident conditions

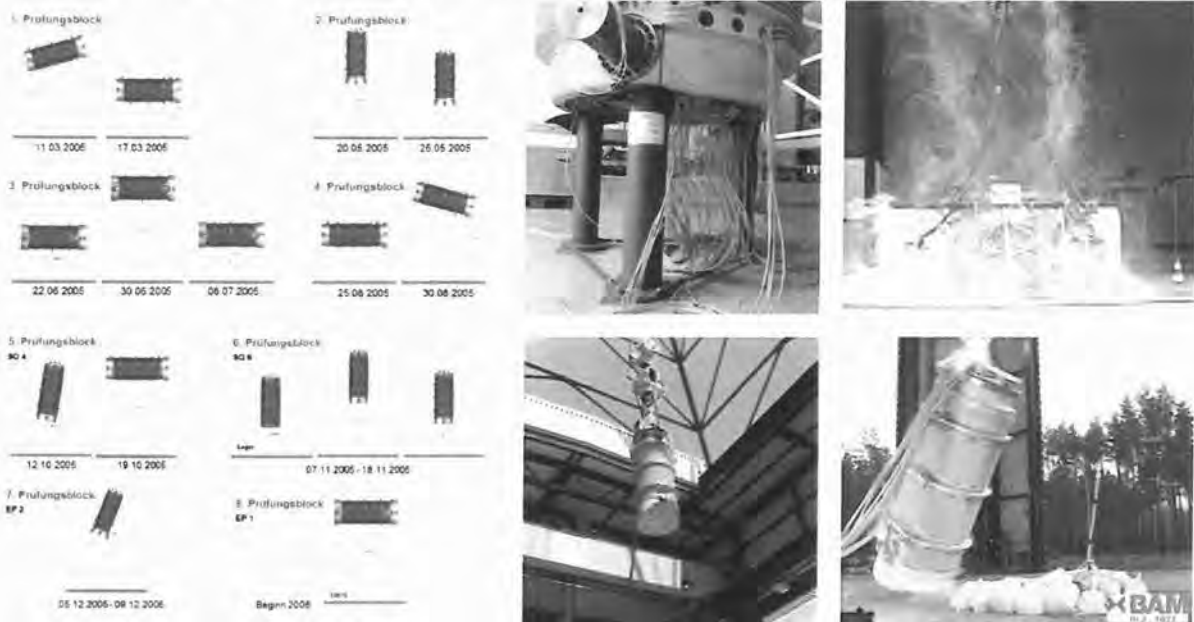

This document may not be cited, reproduced in whole or in part, or made available to third parties without the prior written consent of GNS Gesellschaft für Nuklear-Service mbH, Essen. All rights reserved by GNS. This document contains business and trade secrets of GNS.

2019-02-21 / Pre-Application Meeting NRC / 45

## Codes & Standards – Mechanics

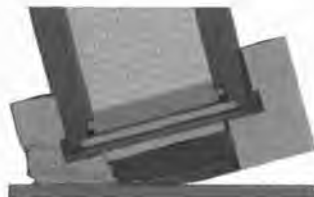

### Design Calculations

- Numerical FE-codes
  - LS DYNA® (dynamic), ANSYS® (quasi-static)
- Analytical calculations
- International standards like FKM-Guideline, VDI etc.

### Experimental base, e.g.

- GNS has executed more than 100 drop tests (9 m, pin drop) on unyielding targets
- Drop test program DROPrund (2009 – 2012)
  - Validation of numerical calculations for cylindrical impact limiters with German competent authority
- Drop test program CASTOR® HAW/TB2 (2005)
  - 17 drop tests for transport and storage licenses with 1:2 scale model
- Material and component tests, e.g.
  - Wall segments, basket segments, bolts, gaskets
  - Material behaviour (ductile cast iron, stainless steel ...)

All applied codes are verified by several cask and component tests.



This document may not be cited, reproduced in whole or in part, or made available to third parties without the prior written consent of GNS Gesellschaft für Nuklear-Service mbH, Essen. All rights reserved by GNS. This document contains business and trade secrets of GNS.

2019-02-21 / Pre-Application Meeting NRC / 46



## Codes & Standards – Thermal



Calculation (3D CFD)

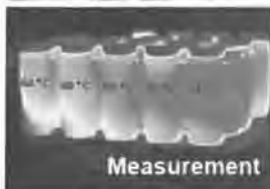

Measurement



### Design Calculations

- ANSYS®-THERMAL, Version 15
- FLUENT from ANSYS®-CFD

### Experimental base

- Validation of ANSYS®-THERMAL with examples from SANDIA-Benchmarks
- Validation of CFD-methods
  - Comparison with measured cask surface temperatures in the interim storage facility in Gorleben
  - Heat transfer of casks under a cover - Comparison of analytical methods with CFD and experimental results
- Fire tests under accident conditions performed

**Thermal behaviour of CASTOR® concept is tested and approved.**



This document may not be cited, reproduced in whole or in part, or made available to third parties without the prior written consent of GNS Gesellschaft für Nuklear-Service mbH, Essen. All rights reserved by GNS. This document contains business and trade secrets of GNS.

2019-02-21 / Pre-Application Meeting NRC / 47

## Codes & Standards - Nuclear

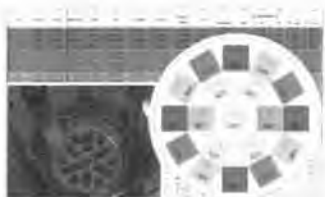

### Codes

- Nuclide inventory
  - SAS2H and ORIGEN-S from the SCALE 5.1
  - WTI programs OBERON and LOAD-CHECK
- Shielding
  - MCNP6 Ver 1.0
  - ENDF/B-VII continuous energy cross section data
- Criticality
  - KENO-VI from SCALE 5.1 code package
  - 238-group ENDF/B-V cross section data
  - CENTRM/PCM for self shielded resonance cross sections

### Validation

- Comparison of the measured and calculated values for CASTOR® V casks with similar design properties
- Benchmark experiments from ICSBEP Handbook (International Criticality Safety Benchmark Evaluation Project - ICSBEP)

**The applied codes are verified by international benchmarks and measurements on loaded casks.**



This document may not be cited, reproduced in whole or in part, or made available to third parties without the prior written consent of GNS Gesellschaft für Nuklear-Service mbH, Essen. All rights reserved by GNS. This document contains business and trade secrets of GNS.

2019-02-21 / Pre-Application Meeting NRC / 48

## Criticality Safety – Code and Validation

- Validation by statistical analyses of ICSBEP benchmark experiments
  - 9 LEU-COMP-THERM experiments with 138 critical rod configurations (thermal neutron spectra with uranium fuel)
  - 6 MIX-COMP-THERM experiments with 79 critical rod configurations (thermal neutron spectra with MOX fuel)
  - Different absorber materials between the fuel rods



Validation provides uncertainty of the code as a contribution to  $\Delta k_U$

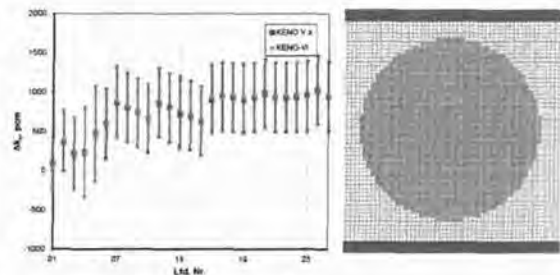

This document may not be cited, reproduced in whole or in part, or made available to third parties without the prior written consent of GNS Gesellschaft für Nuklear-Service mbH, Essen. All rights reserved by GNS. This document contains business and trade secrets of GNS.

2019-02-21 / Pre-Application Meeting NRC / 49

## Inventory – Methods and Codes

- Main objective
  - Neutron (NSS) and gamma source strength (GSS)
  - Decay heat (DH) and radionuclide activities
- Methods and codes
  - 1D-transport code SCALE/SAS2 from Oak Ridge National Laboratory (ORNL)
  - 2D-transport codes
    - SCALE/TRITON from ORNL
    - HELIOS from Studsvik Scandpower
  - Burnup and Decay
    - SCALE/ORIGEN-S
- Typical fuel parameters
  - Enrichment up to 4,9 wt.-%  $^{235}\text{U}$
  - Burnup: typical 60 - 65 GWd/t<sub>HM</sub> up to 80 GWd/t<sub>HM</sub>

SCALE/TRITON-Model

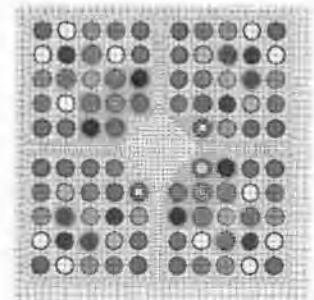

SCALE/SAS2-Model  
UOX MOX

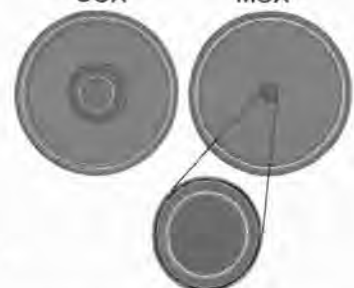

This document may not be cited, reproduced in whole or in part, or made available to third parties without the prior written consent of GNS Gesellschaft für Nuklear-Service mbH, Essen. All rights reserved by GNS. This document contains business and trade secrets of GNS.

2019-02-21 / Pre-Application Meeting NRC / 50

## Conclusion

- The CASTOR® design is proven and internationally accepted for transport and storage ✓
- GNS has more than 35 years of experience with CASTOR® casks and is a reliable partner for long-term future activities ✓
- The CASTOR® geo69 is based on the established CASTOR® concept ✓
- The used codes and methodologies are verified by several casks, component tests, benchmarks and measurements on loaded casks ✓
- A established quality management plan will meet the specific requirements of NRC according to 10CFR71, Subpart H ✓

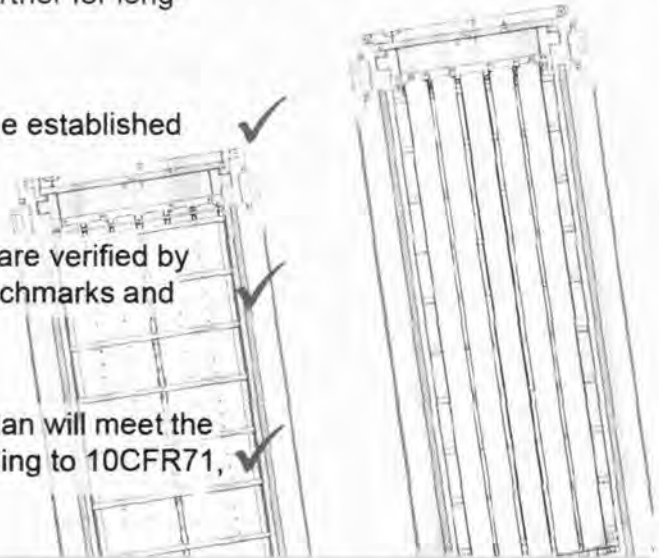

GNS

This document may not be cited, reproduced in whole or in part, or made available to third parties without the prior written consent of GNS Gesellschaft für Nuklear-Service mbH, Essen. All rights reserved by GNS. This document contains business and trade secrets of GNS.

2019-02-21 / Pre-Application Meeting NRC / 51



## Package Components





## Cask Body – DCI - Material Tests

- **Determination of the fracture toughness of DCI at -40 °C (since 2004)**

- The dynamic fracture toughness is required for fracture mechanical evaluation
- Exclusion of unstable crack propagation under dynamic loads

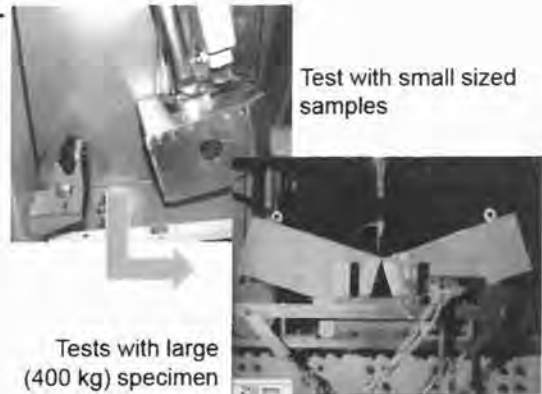

- **Main Results**

- Database of fracture toughness values and correlations between microstructure and strength
- Influence of sample size and establishing of a specific test method

Tests with large (400 kg) specimen

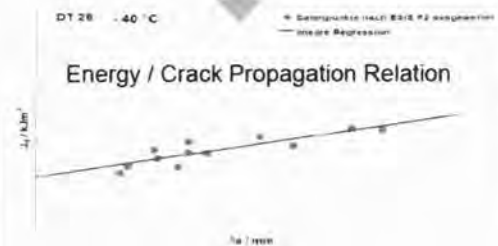

**Verified lower bound value for fracture toughness under dynamic loads at low temperature.**



This document may not be cited, reproduced in whole or in part, or made available to third parties without the prior written consent of GNS Gesellschaft für Nuklear-Service mbH, Essen. All rights reserved by GNS. This document contains business and trade secrets of GNS.

2019-02-21 / Pre-Application Meeting NRC / 55

## Lid System - Metallic Gasket



The Helicoflex® gasket is a self-aligning, self-sealing, self-compressing gasket. It is made of a special alloy steel and is designed to provide a reliable seal under high pressure and temperature. The gasket is used in a wide range of applications, including nuclear power plants, chemical processing, and oil and gas production.

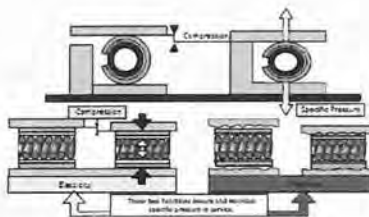

- **Commercial Component, which is established as gasket for nuclear applications.**

- Typ B(U) transportation packages
- storage systems for spent fuel
- Reactor pressure vessels

- **Metallic gasket serves for**

- High degree of tightness ( $10^{-8}$  Pa m<sup>3</sup>/s)
- Longterm stability and function
- Broad range of application experience gained by GNS since 40 years of application with loaded CASTOR® casks

- **Material has already been accepted by NRC within 10CFR71 and 10CFR72 licencing cases**

- 72-1000 – CASTOR® V/21 stored onsite of NPP Surry / USA



This document may not be cited, reproduced in whole or in part, or made available to third parties without the prior written consent of GNS Gesellschaft für Nuklear-Service mbH, Essen. All rights reserved by GNS. This document contains business and trade secrets of GNS.

2019-02-21 / Pre-Application Meeting NRC / 56

## Lid System – Material Test

- Long-term tests at laboratory of CEA/Technetics Pierrelatte, France (2012 – 2018)
- Prognosis about the long-term characteristic of the used metallic gaskets
- Time-dependent behaviour of:
  - Restoring seal force  $Y_1$
  - Useful elastic recovery  $r_u$



Knowledge of the time evolution of main sealing parameters of the used gaskets over a period of more than 40 years.

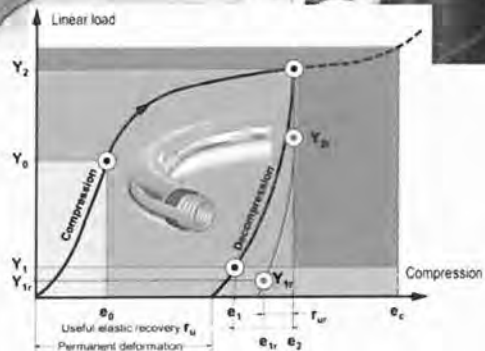

This document may not be cited, reproduced in whole or in part, or made available to third parties without the prior written consent of GNS Gesellschaft für Nuklear-Service mbH, Essen. All rights reserved by GNS. This document contains business and trade secrets of GNS.

2019-02-21 / Pre-Application Meeting NRC / 57

## Lid System – Component Tests

- Testing of lateral displacement of the lids (2011 – 2014)
- Time-dependent recovery of leakage rate after impact within one week
- Even for extreme lateral movements of the lid up to 5 mm
  - Bolting assures sufficient pre-stress
  - Gasket remains sufficiently tight



Under extrem mechanical conditions the lid system maintains its integrity.

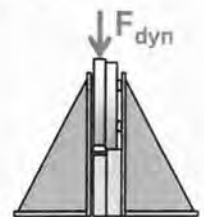
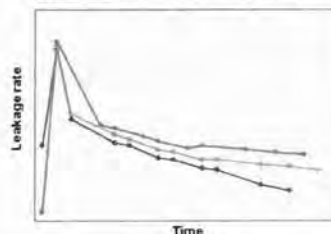

This document may not be cited, reproduced in whole or in part, or made available to third parties without the prior written consent of GNS Gesellschaft für Nuklear-Service mbH, Essen. All rights reserved by GNS. This document contains business and trade secrets of GNS.

2019-02-21 / Pre-Application Meeting NRC / 58

## Lid System – Cask Tests

- Examination of the lid system after drop, measuring of the
  - Leakage rate
  - Remaining pre-stress in the bolts
  - Roughness of the sealing surfaces
  - Lid displacement

Verified leakage rates under accident conditions.



This document may not be cited, reproduced in whole or in part, or made available to third parties without the prior written consent of GNS Gesellschaft für Nuklear-Service mbH, Essen. All rights reserved by GNS. This document contains business and trade secrets of GNS.

2019-02-21 / Pre-Application Meeting NRC / 59

## Impact Limiter – Polyurethan Foam



WHERE GREAT IDEAS TAKE SHAPE.

LAST-A-FOAM® FR-3700  
PERFORMANCE CORE SERIES

LAST-A-FOAM® FR-3700 is a CFC-free, rigid closed-cell flame-retardant polyurethane foam available in densities ranging from 3 to 45 pounds per cubic foot. Tougher and less flammable than other rigid foam materials, this aerospace-grade, 80/20 polyurethane foam enables cutting of complex shapes, making it well-suited to machining complex shapes for composite cores. It exhibits a high strength-to-weight ratio due to its cellular structure and cross-linked resin. Because of its closed-cell structure, FR-3700 has excellent resistance to water absorption and will not swell, crack, or split on exposure to water. The FR-3700 series provides exceptional protection for hazardous cargo and payloads as an impact and fire-insulation liner in transport or packaging containers. It also serves as human bone rest media.

#### CHEMICAL RESISTANCE

LAST-A-FOAM® products exhibit very good resistance to a wide range of chemicals and solvents. Common petroleum products such as oil or gasoline have no effect on LAST-A-FOAM. Our products are thermally resistant, but are resistant to fungal growth and will not break down over time. If you need specific advice regarding chemical resistance, please contact us.

#### MATERIAL HANDLING & SAFETY STORAGE

Rigid LAST-A-FOAM® should be stored as any other combustible organic solid. Storage precautions for wood are adequate. Solids and waste LAST-A-FOAM® materials are inert and can be disposed of as ordinary solid waste. However, cutting, grinding, abrading, routing, and sanding LAST-A-FOAM® produces dust. The rubbing of foam dust, as with any dust, should be avoided. Safety measures appropriate for use in handling dust inhalation should be used when working with LAST-A-FOAM®.

#### FIRE SAFETY

Although LAST-A-FOAM® rigid polyurethane foam is flame resistant, it is an organic material which will burn in the presence of enough heat and oxygen. The Federal Aviation Regulation (FAR) 25.853 flame test is commonly used to assess the retail burning characteristics of foam plastic materials under controlled laboratory conditions. LAST-A-FOAM® FR-3700 meets the FAR 25.853 12-second and 30-second ignition requirements.

#### FEATURES & BENEFITS

- Dimensionally stable
- Chemically inert
- Resistant to most chemicals and solvents
- Highly moldable
- Easily shaped with common woodworking tools
- Performs well as wood replacement
- High strength-to-weight ratio from cross-linked resin
- Flame resistant

#### POTENTIAL APPLICATIONS

- Molds and design prototypes
- Composite core
- Interior sandwich panels used in overhead storage bins, passenger cabin cases, dividers, galleys and lavatories
- Jacobson form deck and mold patterns

#### CERTIFICATIONS & QUALITY SYSTEMS

ISO 9001:2015/AS 9100  
NQA-1  
9001:2008  
Bleking Company DS-02473  
ITAR-Compliant  
Nuclear 4C7130 Rev C  
NABOP ACT 1301 Rev A

- Commercial Material, which is established as impact absorbing material for Typ B(U) transportation packages.

- Material has already been accepted by NRC within a 10CFR71 licencing case

Examples (limited set) of licensed Radioactive Material Packages using LAST-A-FOAM® FR-3700

Package Model No.: TRUPACT II US Certificate No.: USA/9218/B(U)F-85 Licensee: U.S. Department of Energy	Package Model No.: RH-TRU 75-B US Certificate No.: USA/9212/B(U)F-85 Licensee: U.S. Department of Energy
Package Model No.: 125-B US Certificate No.: USA/9200/B(U)F-85 Licensee: U.S. Department of Energy	Package Model No.: NUHOMS® MP187 Multi-Purpose Cask US Certificate No.: USA/9255/B(U)F-85 Licensee: Transnuclear, Inc.
Package Model No.: F-423 US Certificate No.: USA/9299/B(U)-85 Licensee: MDS Nordisk	Package Model No.: Traveller STD and Traveller XLR US Certificate No.: USA/9279/AF-96 Licensee: Westinghouse Electric Company
Package Model No.: UX-30 US Certificate No.: USA/9196/B(U)-85 Licensee: Duratek	Package Model No.: New Powder Container (NPC) US Certificate No.: USA/9294/AF-96 Licensee: Global Nuclear Fuel

4410 Burroughs Way Tacoma, WA 98409 PH: 800.309.5201/INTL: 252.473.5800 | general@gnsl.com



This document may not be cited, reproduced in whole or in part, or made available to third parties without the prior written consent of GNS Gesellschaft für Nuklear-Service mbH, Essen. All rights reserved by GNS. This document contains business and trade secrets of GNS.

2019-02-21 / Pre-Application Meeting NRC / 60

## Impact Limiter – Cask Tests

- Drop test programme with cylindrical impact limiter for validation test
  - Drop tests with CASTOR® V/TB1a half scale model based on CASTOR® V/19 and CASTOR® V/52
- 4 drop tests
  - For all relevant orientations
  - At operation temperature range (up to 80 °C)

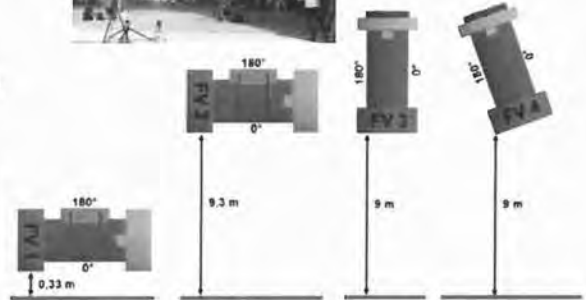

**Experimental database for verification established.**



This document may not be cited, reproduced in whole or in part, or made available to third parties without the prior written consent of GNS Gesellschaft für Nuklear-Service mbH, Essen. All rights reserved by GNS. This document contains business and trade secrets of GNS.

2019-02-21 / Pre-Application Meeting NRC / 61

## Impact Limiter – Cask Tests

- Comparison between calculation and drop test
- FEM simulation
- High-speed picture of the drop test

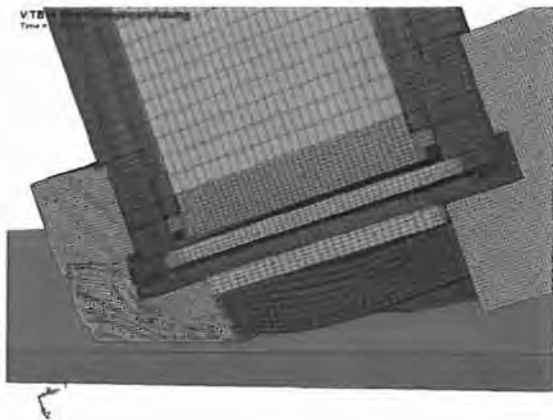

**The applied numerical model is reliable for the simulation of high dynamic impacts with large deformations.**



This document may not be cited, reproduced in whole or in part, or made available to third parties without the prior written consent of GNS Gesellschaft für Nuklear-Service mbH, Essen. All rights reserved by GNS. This document contains business and trade secrets of GNS.

2019-02-21 / Pre-Application Meeting NRC / 62



# Basket Material – Boronated Aluminium MMC

Proprietary Information withheld per 10CFR2.390

EPRI

Handbook of Neutron Absorber Materials for Spent  
Nuclear Fuel Transportation and Storage Applications  
2009 Edition



- Basket Material serves for
  - Geometrical boundary for lodgement carrying the F/A
  - Neutron absorption function to maintain subcriticality
  - Thermal conductivity
  - Structural stability under all conditions of design
- Boronated Aluminium Alloy as Metall Matrix Compound (MMC)
  - 10 wt.-% of B4C
  - [REDACTED]
  - No degradation during ageing due to thermal treatment before use
    - Time-independant structural properties
  - Candidate material:
    - [REDACTED]



This document may not be cited, reproduced in whole or in part, or made available to third parties without the prior written consent of GNS Gesellschaft für Nuklear-Service mbH, Essen. All rights reserved by GNS. This document contains business and trade secrets of GNS.

2019-02-21 / Pre-Application Meeting NRC / 63

# Moderator Material – Polyethylen

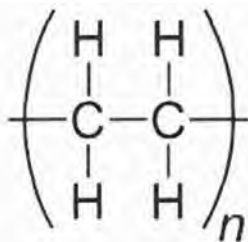

- Commercial Component, which is established as neutron moderator for nuclear applications.
  - Typ B(U) transportation packages
  - storage systems for spent fuel
- Polyethylene serves for
  - Efficient moderation of neutron within the cask body
    - Highest partial density of hydrogen within a solid material
    - Cylindrical rods in deep bore holes
    - Plates between the lids and in the cask bottom
  - Broad range of application experience gained by GNS since 40 years of application with loaded CASTOR® casks
- Material has already been accepted by NRC within 10CFR71 and 10CFR72 licencing cases
  - 72-1000 – CASTOR® V/21 stored onsite of NPP Surry / USA



This document may not be cited, reproduced in whole or in part, or made available to third parties without the prior written consent of GNS Gesellschaft für Nuklear-Service mbH, Essen. All rights reserved by GNS. This document contains business and trade secrets of GNS.

2019-02-21 / Pre-Application Meeting NRC / 64

## Discussion

